

1571

1574

Adjustment Manual

1591

1593

This **Adjustment Manual** applies to machines from the following serial numbers onwards:

7 274 018

Reprinting, copying or translation of PFAFF instruction manuals, whether in whole or in part, is not permitted without our prior permission and not without written indication of the source

**PFAFF Industriesysteme
und Maschinen GmbH**

Hans-Geiger-Str. 12 - IG Nord
D-67661 Kaiserslautern

	Page
Contents	Page
15	
Adjustment	5
15.01 Tools, gauges and other accessories	5
15.02 Abbreviations	5
15.03 Explanation of symbols	5
15.04 Adjusting the basic machine	6
15.04.01 Needle pendulum basic setting	6
15.04.02 Needle position in sewing direction	7
15.04.03 Limiting the needle bar frame (on the PFAFF 1571 and 1591).....	8
15.04.04 Preadjusting the needle height	9
15.04.05 Needle rise, hook clearance, needle height and needle guard (on the PFAFF 1571)	10
15.04.05a Needle rise, hook clearance, needle height and needle guard (on the PFAFF 1574)	11
15.04.06 Needle rise, hook clearance, needle height and needle guard (on the PFAFF 1591 and 1593)	12
15.04.07 Needle position crosswise to sewing direction (on the PFAFF 1571).....	13
15.04.07a Needle position crosswise to sewing direction (on the PFAFF 1574).....	14
15.04.08 Needle position crosswise to sewing direction (on the PFAFF 1591 and 1593).....	15
15.04.09 Height and stroke of the bobbin case opener	16
15.04.10 Height of the feed wheel (on the PFAFF 1571)	17
15.04.10a Height of the feed wheel (on the PFAFF 1574)	18
15.04.11 Height of the feed wheel (on the PFAFF 1591 and 1593)	19
15.04.12 Clearance between roller presser and feed wheel	20
15.04.13 Roller-presser	21
15.04.13a Hold-down device (only with PFAFF 1574).....	22
15.04.14 Automatic presser-foot lifter	23
15.04.15 Knee lever.....	24
15.04.16 Tension release.....	25
15.04.17 Thread check spring (on to PFAFF 1571; 1591 and 1593).....	26
15.04.17a Thread check spring (on the PFAFF 1574).....	27
15.04.18 Thread tension control -906/11 (on the PFAFF 1591)	28
15.04.19 Bobbin winder	29
15.04.20 Roller-presser pressure	30
15.04.21 Lubrication	31
15.04.22 Re-engage safety coupling	32
15.05	
Adjusting the edge trimmer -725/04.....	33
15.05.01 Position of the knife holder (on the PFAFF 1571).....	33

	Contents	Page
15.05.02	Position of the knife holder (on the PFAFF 1574 and 1591).....	34
15.05.03	Knife stroke (on the PFAFF 1571)	35
15.05.04	Knife stroke (on the PFAFF 1574 and 1591)	36
15.05.05	Cutting stroke (on the PFAFF 1571).....	37
15.05.06	Cutting stroke (on the PFAFF 1574 and 1591).....	38
15.05.07	Knife position	39
15.06	Adjusting the thread trimmer -900/81	40
15.06.01	Resting position of the roller lever / radial position of the control cam.....	40
15.06.02	Position of the thread catcher holder	41
15.06.03	Distance between thread catcher and needle plate.....	42
15.06.04	Position of the thread catcher	43
15.06.05	Knife position and knife pressure.....	44
15.06.06	Bobbin thread retaining spring.....	45
15.06.07	Manual cutting test.....	46
15.06.08	Linkage rod (only on the PFAFF 1574).....	47
15.07	Parameter settings.....	48
15.07.01	Overview of parameter functions (with BDF S5).....	48
15.07.02	Overview of parameter functions (with BDF P1).....	49
15.07.03	Parameter input example (with BDF S5)	50
15.07.04	Parameter input example (with BDF P1)	51
15.07.05	Parameter list for control P430SD	53
15.08	Error Messages and Description	58
15.09	Sewing motor errors	60
15.10	Warning messages	60
15.11	Update (with SD card or USB).....	61
16	Circuit diagrams.....	62

15 Adjustment



Please observe all notes from Chapter **1 Safety** of the instruction manual!
In particular care must be taken to see that all protective devices are refitted properly after adjustment, see Chapter **1.06 Danger warnings** of the instruction manual!



If not otherwise stated, the machine must be disconnected from the electrical power supply. Danger of injury due to unintentional starting of the machine!

Notes on adjustment

All following adjustments are based on a fully assembled machine and may only be carried out by expert staff trained for this purpose.

Machine covers, which have to be removed and replaced to carry out checks and adjustments, are not mentioned in the text.

The order of the following chapters corresponds to the most logical work sequence for machines which have to be completely adjusted. If only specific individual work steps are carried out, both the preceding and following chapters must be observed.

Screws, nuts indicated in brackets () are fastenings for machine parts, which must be loosened before adjustment and tightened again afterwards.

15.01 Tools, gauges and other accessories for adjusting

- Screwdrivers with blade width from **2** to **10 mm**
- Spanners (wrenches) with jaw width from **7** to **14 mm**
- **1** set Allen keys from **1.5** to **6 mm**
- **1** metal ruler (Part no. **08-880 218-00**)
- **1** adjustment gauge (Part No. **08-880 136-01**)
- **1** adjustment gauge (Part No. **61-111 600-35**)
- **1** adjustment pin (needle position in direction of sewing Part no. **61-111 641-46**)

15.02 Abbreviations

t.d.c = top dead center

b.d.c = bottom dead center

15.03 Explanation of the symbols

In this adjustment manual, symbols emphasize operations to be carried out or important information. The symbols used have the following meaning:



Note, information

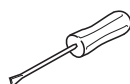

Service, repair, adjustment, maintenance
(work to be carried out by qualified staff only)

Adjustment

15.04 Adjusting the basic machine

15.04.01 Needle position in the direction of sewing

Requirement

The screw 4 from the needle pendulum should be flush with the bracket 5

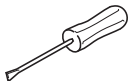
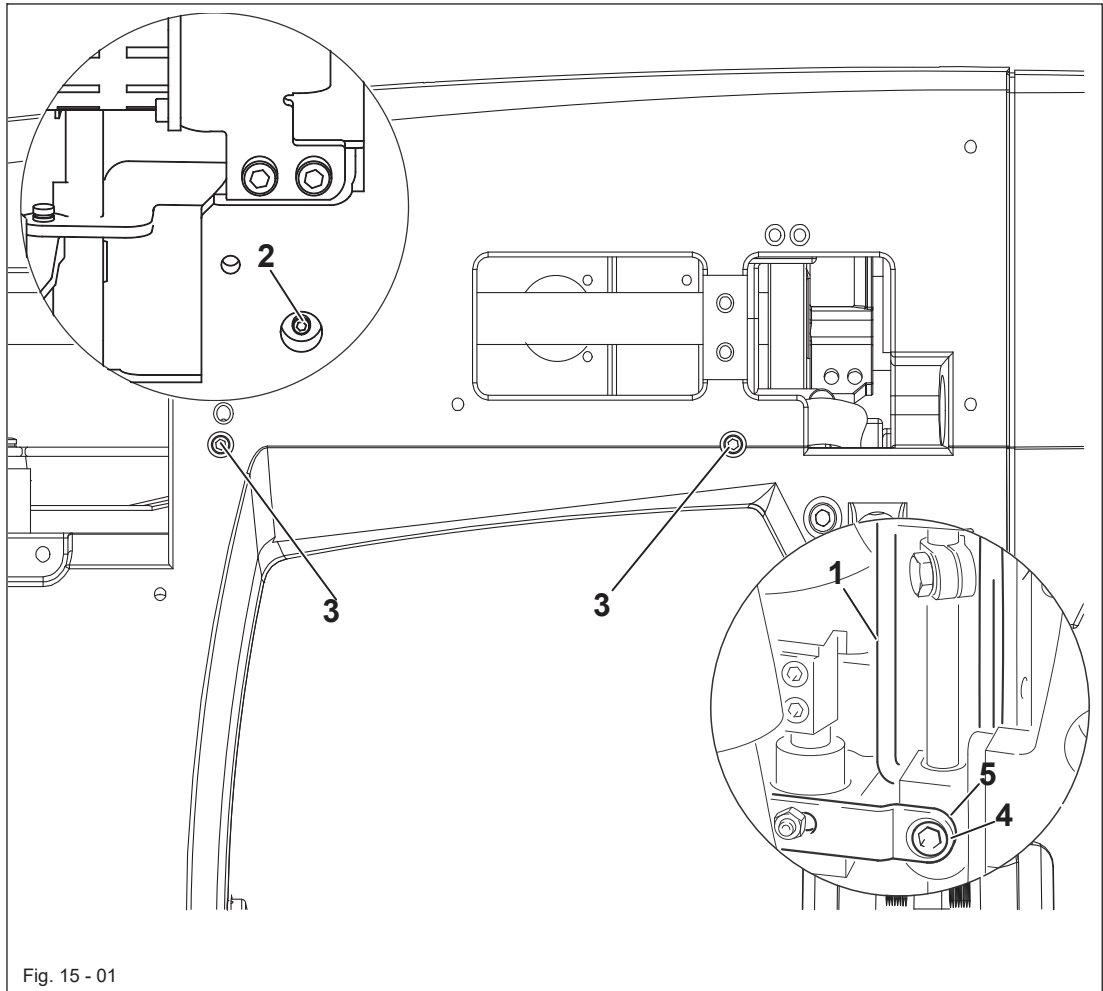

➡ Move the needle bar frame 1 (screws 2 and 3) in accordance with the **requirement**.



Screws 3 are accessible through the holes on the back of the housing.

15.04.02 Needle position in the direction of sewing

Requirement

With the stitch length set at "5", in its front and rear point of reversal the needle should be the same distance from the inside edges of the needle hole.

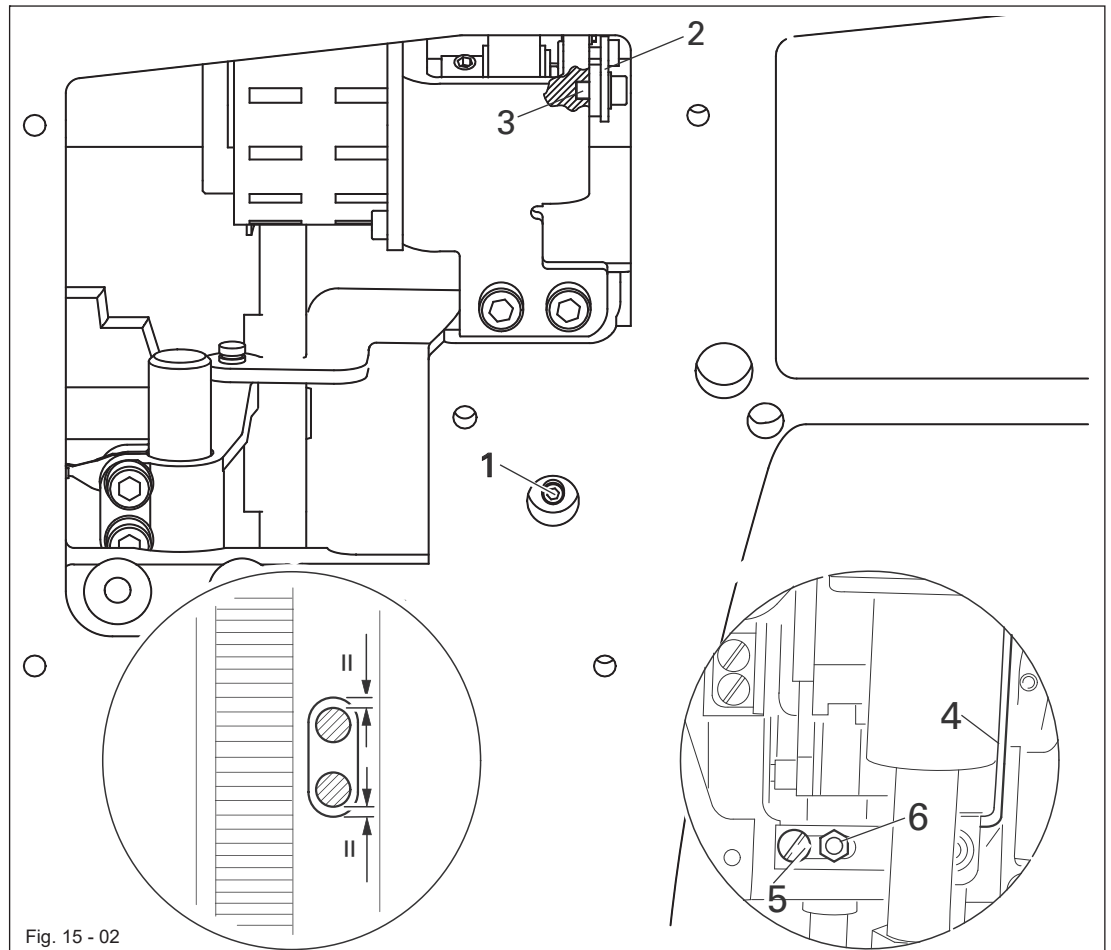
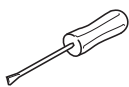

Fig. 15 - 02



- Switch on the machine and set the stitch length at "5".
- Switch the machine off and on (synchronization of the needle bar to the stitch length).
- Sew one stitch and check the rear position of the needle in accordance with the requirement.
- Pedal max. press backwards!
- Press the stitch changeover key and check the front and rear position of the needle in accordance with the requirement.
- Switch off the machine, slightly loosen screw 5 and nut 6.
- To carry out the adjustment, loosen screw 1 through the hole on the back of the case.
- Guide the bent part of the adjustment pin through the elongated hole on the rear side of the case and insert it into hole 3 through the hole in lever 2.
- Adjust the needle bar frame 4 (screw 1) in accordance with the requirement.
- Check: switch on the machine and sew a stitch. Pedal max. Actuate backwards and check needle front and rear position!



Screw 5 and nut 6 remain loosened for the next adjustment

Requirement

With the stitch length set at "5", when the needle is in its front and rear point of reversal screw 4 should be the same distance from the inside edge of its hole.

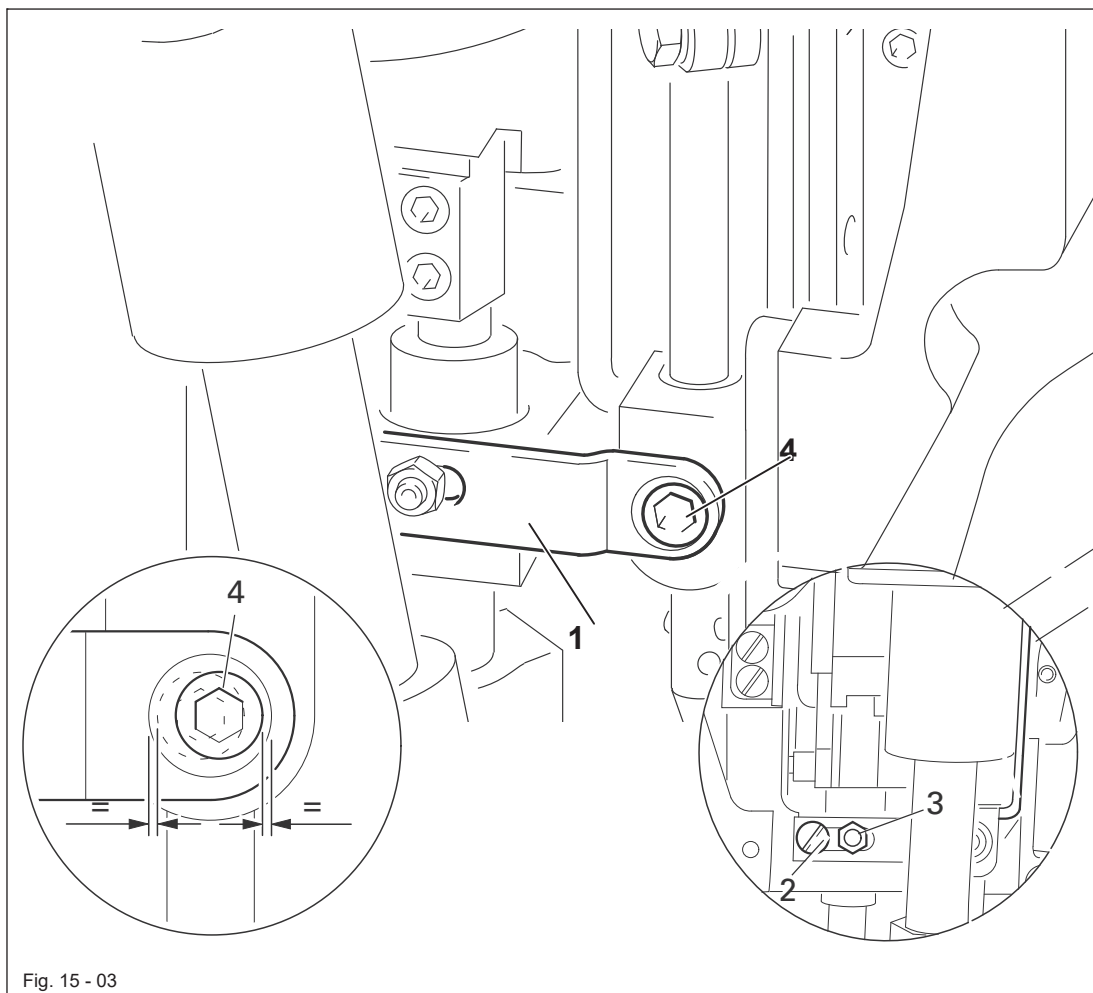
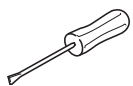

Fig. 15 - 03



- ➡ Switch on the machine and set the stitch length at "5".
- ➡ Sew one stitch and check the rear position of screw 4 in accordance with the **requirement**.
- ➡ Operate the reverse feed key, sew one stitch and check the front position of screw 4 in accordance with the **requirement**.
- ➡ To carry out the adjustment shift plate 1 (screw 2 and nut 3) in accordance with the **requirement**.

15.04.04 Preadjusting the needle height

Requirement

With the needle bar at TDC there must be approx. **25 mm** between the point of the needle and the needle plate.

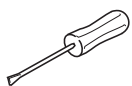
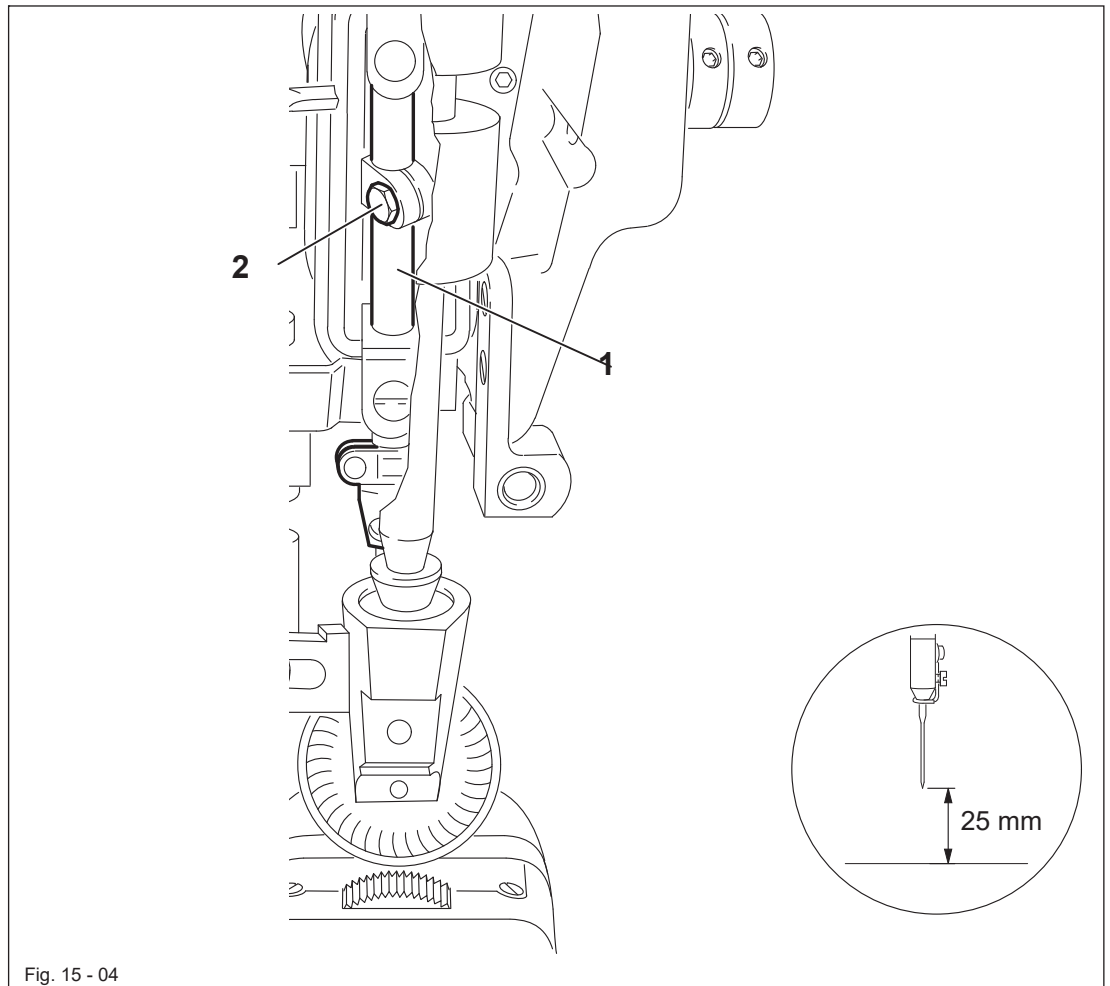

➡ Move the needle bar **1** (screw **2**) in accordance with the **requirement** without turning it.

Adjustment

15.04.05

Needle rise, hook clearance, needle height and needle guard (on the PFAFF 1571)

Requirement

With the needle bar positioned **2.0 mm** after BDC and the stitch length set at **"0.8"**

1. the hook point must be at needle centre with a hook-to-needle clearance of **0.05 to 0.1 mm**;
2. the top of the needle eye must be **0.8 to 1.0 mm** below the hook point;
3. the needle guard **5** must touch the needle lightly.

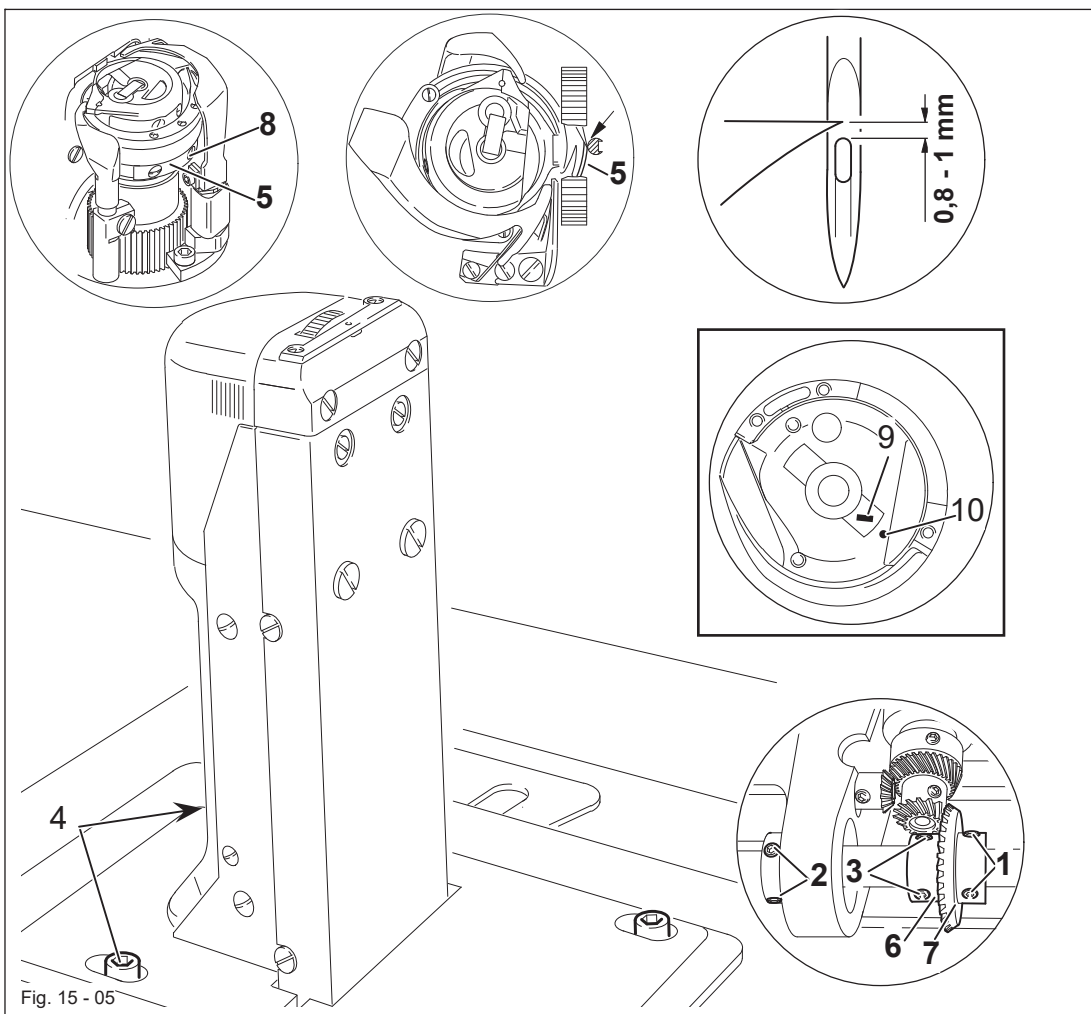
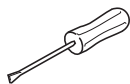

Fig. 15 - 05



- Turn on the machine
- Set the stitch length to "0.8" and sew 3 stitches.
- Turn off the machine
- Loosen both screws **1, 2, 3** and **4**.
- Bring the needle bar to **2.0 mm** after b.d.c. and place the locking pin for the needle bar
- Set the hook point to the centre of the needle, taking care to see that the needle is not deflected by needle guard **5**.
- Adjust needle height according to Requirement **2**.
- Adjust hook post according to Requirement **1** and tighten screws **4** and **2**.
- Making sure that there is some play in the bevel gear, tighten screws **1**.
- With retaining collar **6** touching bevel gear **7** tighten screws **3**.
- Adjust needle guard **5** (screw **8**) in accordance with **requirement 3**.



When the hook is changed, make sure that the markings **9** and **10** are both on one side.

15.04.05a Needle rise, hook clearance, needle height and needle guard (on the PFAFF 1574)

Requirement

With the needle bar positioned **2,4 mm** after BDC on both hooks

1. the hook point must be at needle centre with a hook-to-needle clearance of **0.05 to 0.1 mm**;
2. the top of the needle eye must be **0.8 to 1.0 mm** below the hook points;
3. the needle guard **9** must touch the needle lightly.

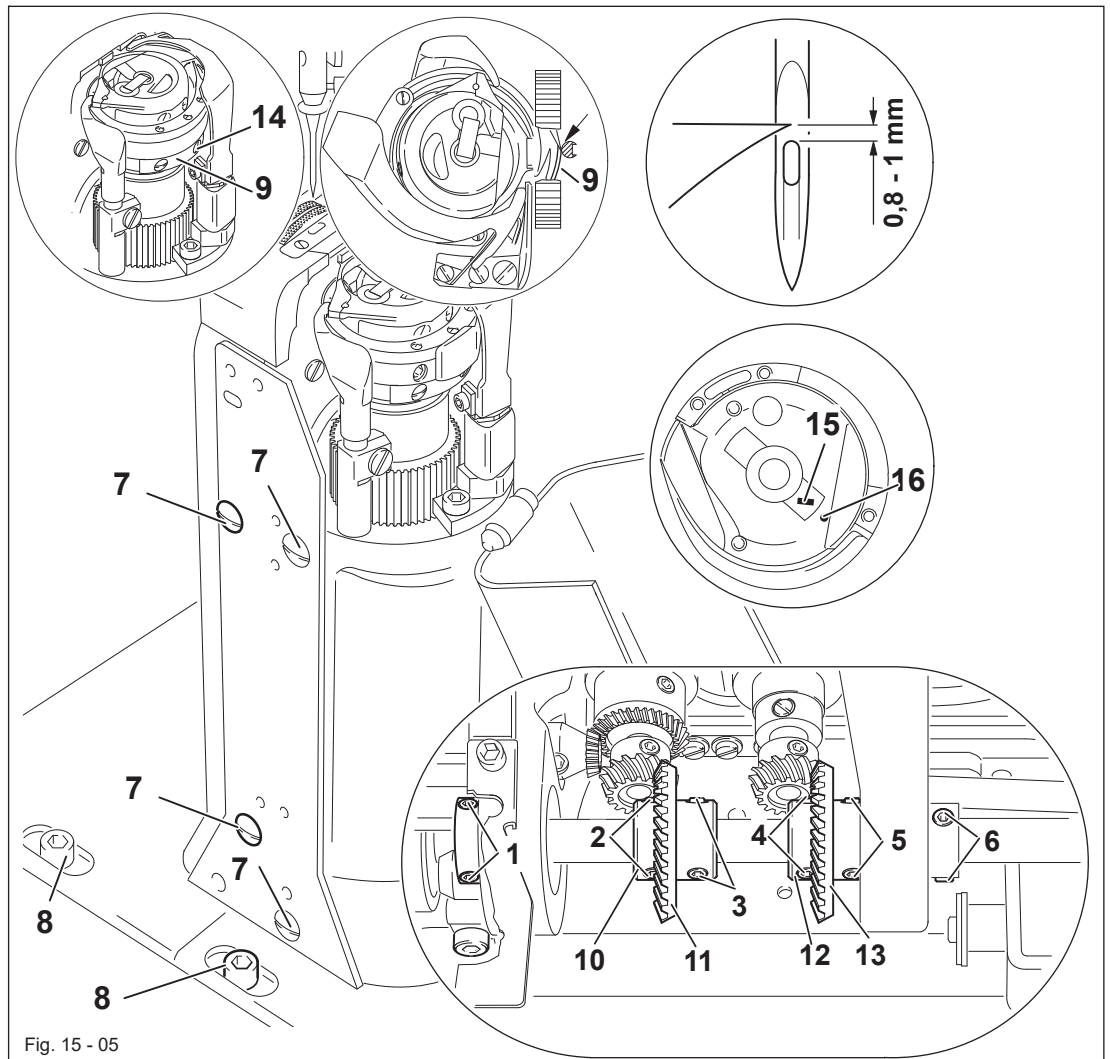

Fig. 15 - 05

- Loosen screws **1, 2, 3, 4, 5, 6** and **7**
- Loosen screws **8** slightly.
- Bring the needle bar to **2.4 mm** after b.d.c.
- Set both hook points to the centre of the needle, taking care to see that the needles are not deflected by needle guard **9**.
- Set the needle height in accordance with **requirement 2**
- Adjust both hook posts in accordance with **requirement 1** and tighten screws **8**.
- Tighten screws **1** and **6**.
- Taking the play of the bevel gear into consideration, tighten screws **3** and **5**.
- Move adjustment ring **10** against bevel gear **11** and tighten screws **2**.
- Move adjustment ring **13** against bevel gear **14** and tighten screws **4**.
- Tighten screws **7** on both sides of the post.
- Adjust needle guard **9** (screw **14**) on both hooks in accordance with **requirement 3**.



When the hook is changed, make sure that markings **15** and **16** are on one side.

15.04.06 Needle rise, hook clearance, needle height and needle guard (on the PFAFF 1591 and 1593)

Regel

With the needle bar positioned **2.0 mm after BDC** and the stitch length set at "**0.8**"(only on the PFAFF **1591**).

1. the hook point must be at needle centre with a hook-to-needle clearance of **0.05 to 0.1 mm**;
2. the top of the needle eye must be **0.8 to 1.0 mm** below the hook point;
3. the needle guard **6** must touch the needle lightly.

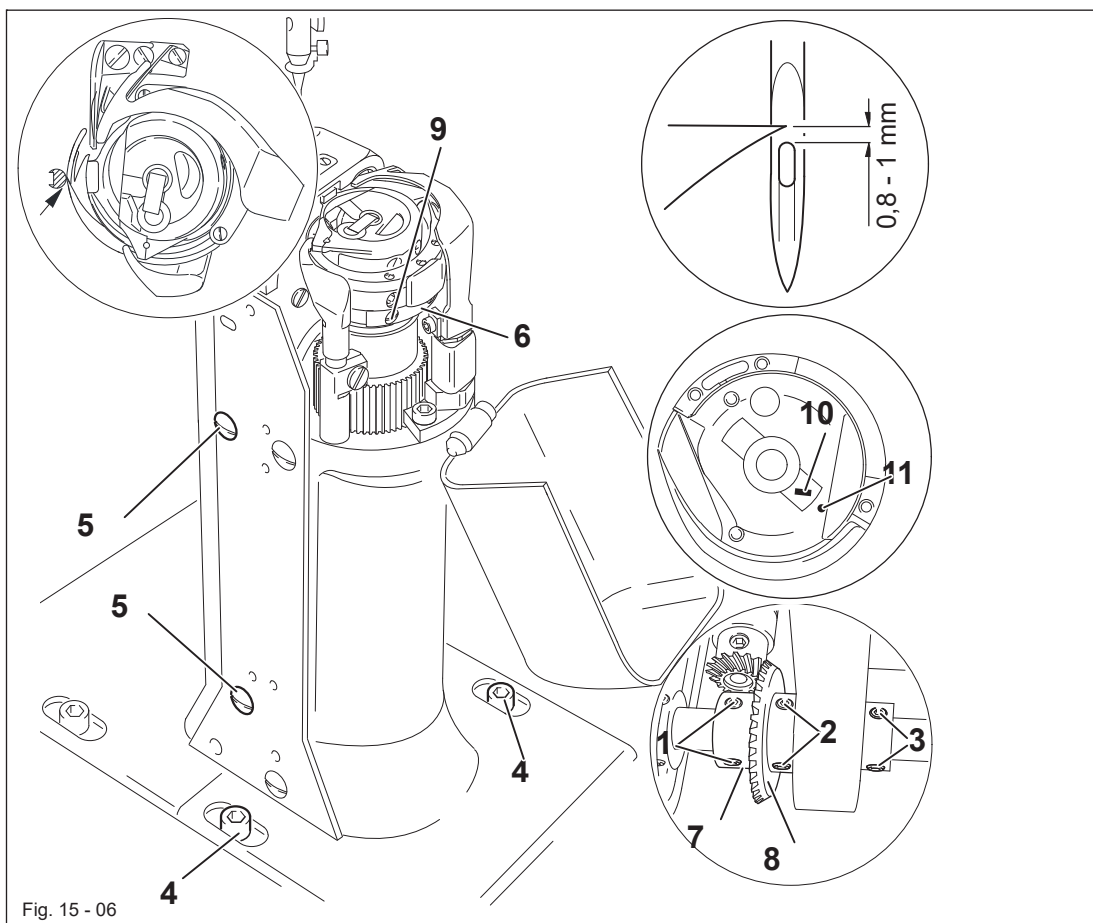
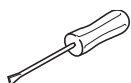

Fig. 15 - 06



- ➡ Turn on the machine
- ➡ Set the stitch length to "0.8" and sew 3 stitches.(only on the PFAFF **1591**).
- ➡ Turn off the machine
- ➡ Loosen both screws **1, 2, 3, 4** and **5**.
- ➡ Bring the needle bar to **2.0 mm** after b.d.c. and place the locking pin for the needle bar
- ➡ Set the hook point to the centre of the needle, taking care to see that the needle is not deflected by needle guard **6**.
- ➡ Adjust needle height according to Requirement **2**.
- ➡ Adjust hook post according to Requirement **1** and tighten screws **4** and **3**.
- ➡ Making sure that there is some play in the bevel gear, tighten screws **2**.
- ➡ With retaining collar **7** touching bevel gear **8** tighten screws **2** and **3**.
- ➡ Screws **5** remain loose for further settings.
- ➡ Adjust needle guard **6** (screw **9**) in accordance with **requirement 3**.



When the hook is changed, make sure that the markings **10** and **11** are both on one side.

15.04.07 Needle position crosswise to sewing direction (on the PFAFF 1571)

Requirement

For maximum stitch length adjustment, the needle should stand in the middle of the needle hole both when entering and exiting the throat plate.

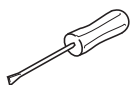
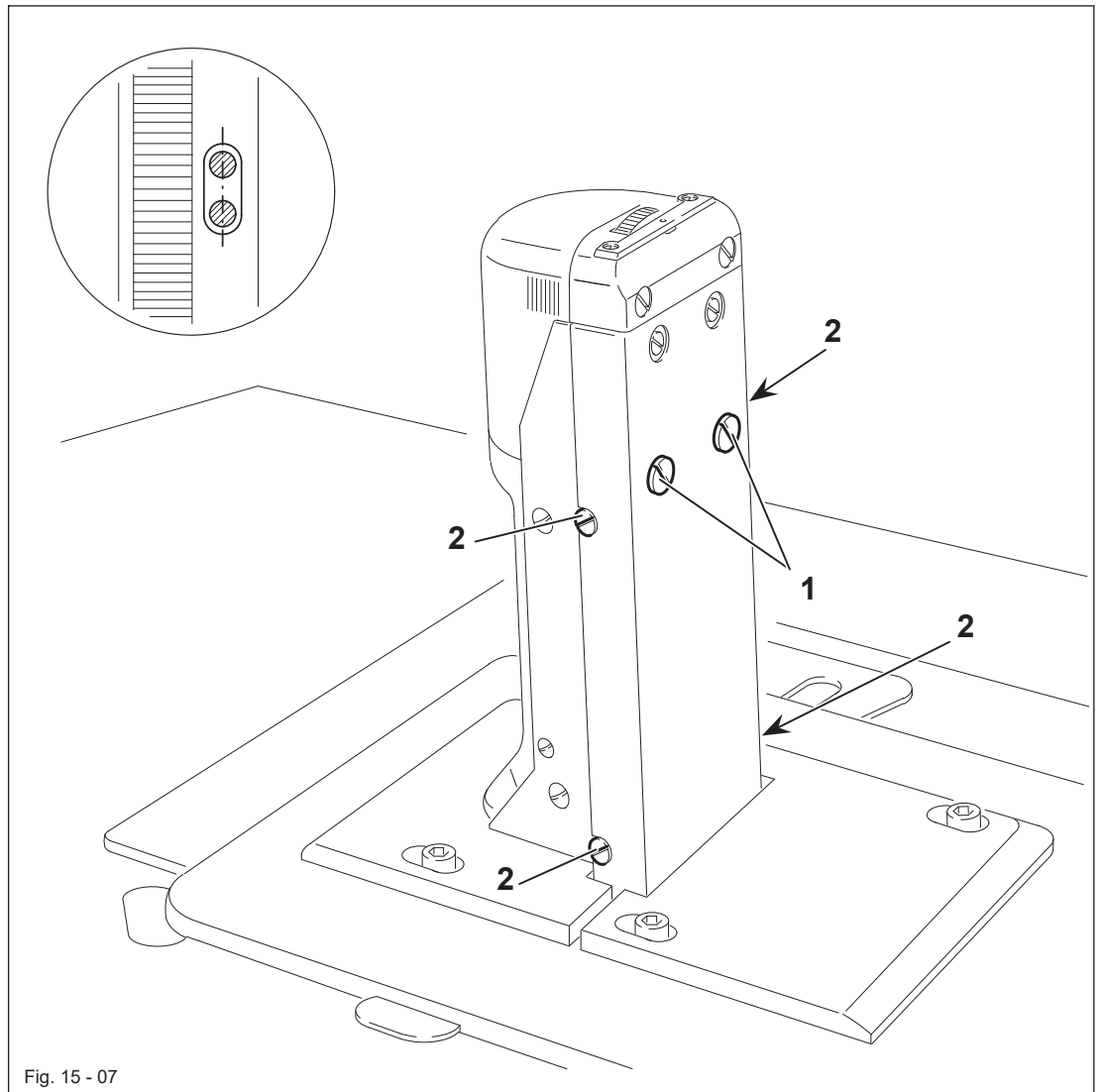

► Turn screws **1** (screws **2**, on both sides of the column) according to the **rule**.

Adjustment

15.04.07a Needle position crosswise to sewing direction (on the PFAFF 1574)

Requirement

As seen crosswise to the sewing direction, the needles must penetrate in the centre of their needle holes.

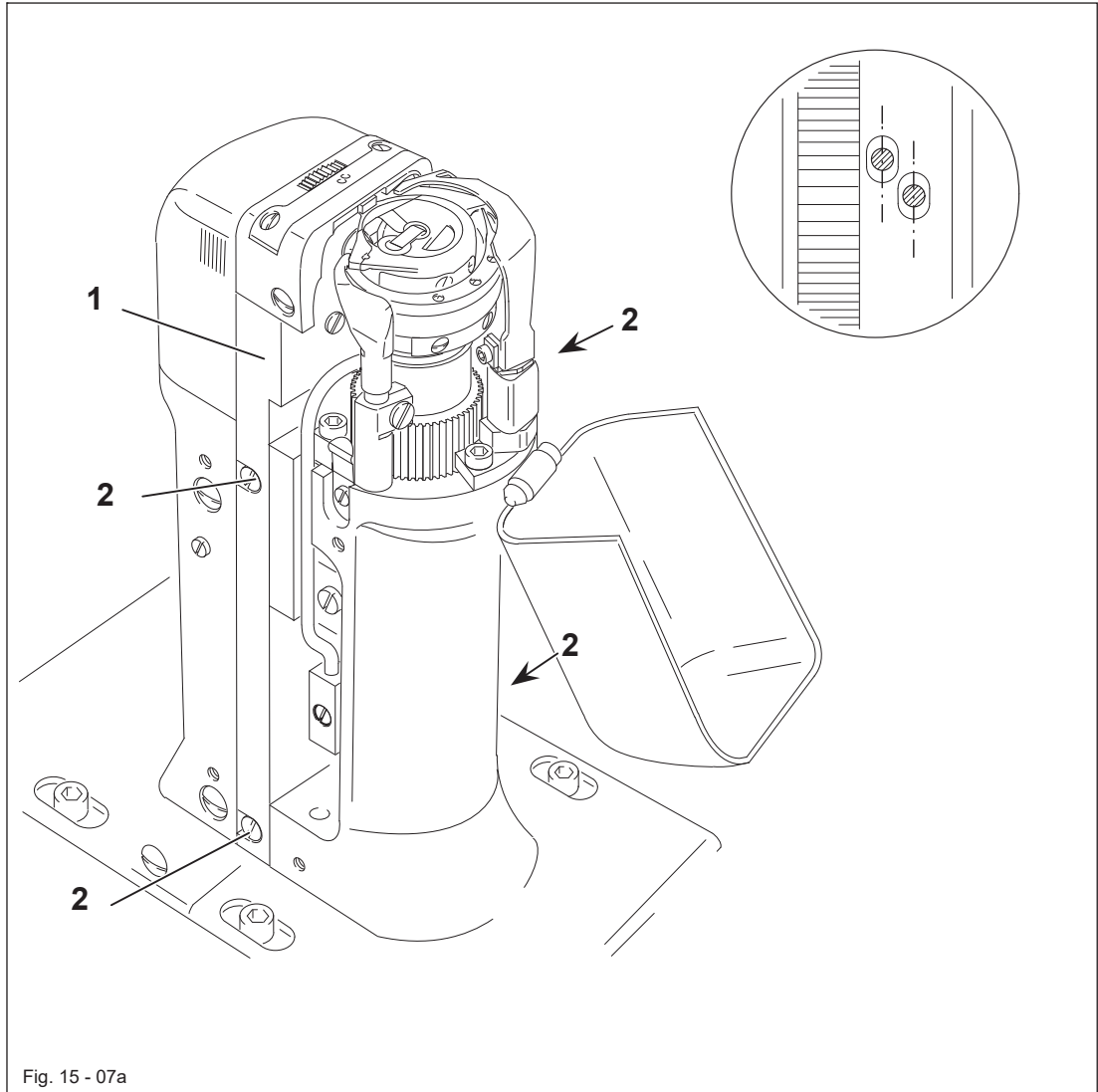
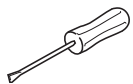

Fig. 15 - 07a



➡ Shift bearing plate 1 (screws 2, on both sides of the post) according to the requirement.

15.04.08 Needle position crosswise to sewing direction (on the PFAFF 1591 and 1593)

Requirement

As seen crosswise to the sewing direction, the needle must penetrate in the centre of the needle hole.

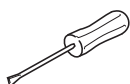
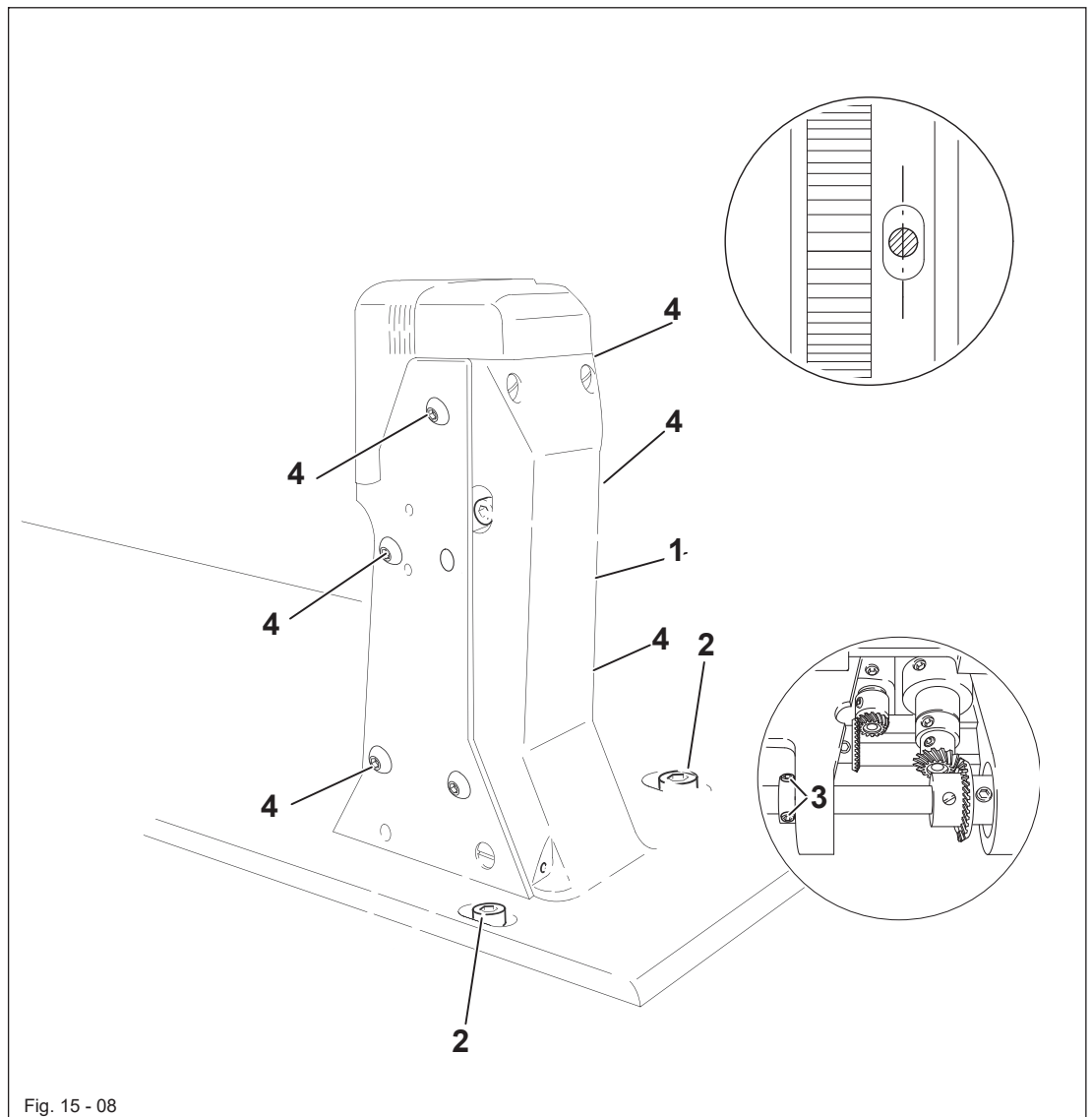

➡ Adjust feed wheel post 1 (screws 2, 3 and 4) according to the **requirement**.

15.04.09 Height and stroke of the bobbin case opener

Requirement

1. The top edges of the bobbin case opener **1** and bobbin case base **3** should be on one level.
2. When the bobbin case opener **1** has deflected the bobbin case to its furthest point, the catch of the bobbin case should be **0.3 - 0.5 mm** from the back edge of the needle-plate recess.

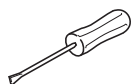
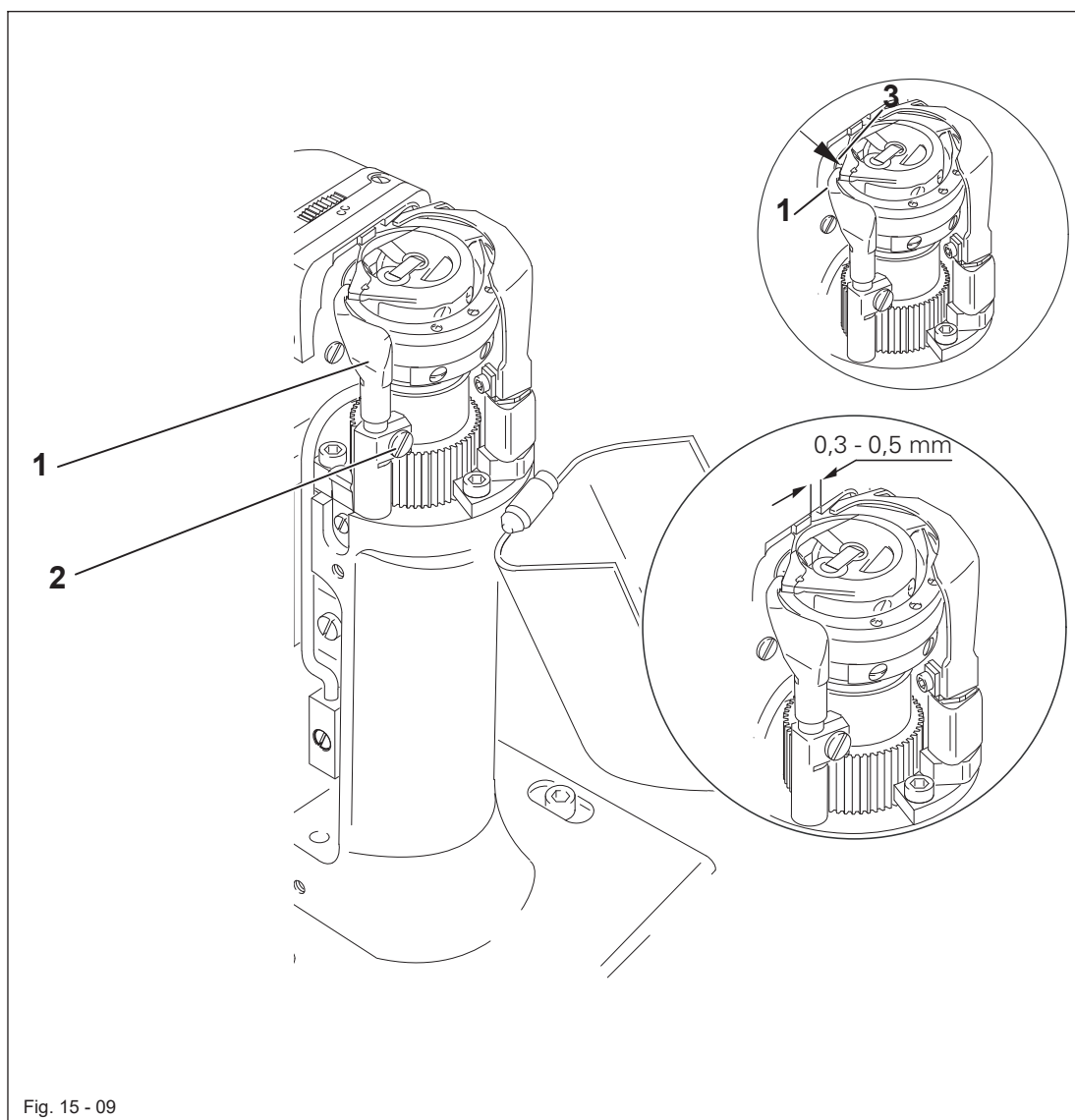

- ➡ Adjust bobbin case opener **1** (screw **2**) in accordance with requirement **1**.
- ➡ Turn the balance wheel until the bobbin case opener has deflected the bobbin case to its furthest point.
- ➡ Adjust bobbin case opener **1** (screw **2**) in accordance with requirement **2**.



Depending on the thread size, a variation of the setting in Requirement **2** is permitted.

15.04.10 Height of the feed wheel (on the PFAFF 1571)

Requirement

1. The loaded sliding wheel 4 should protrude by tooth height (about **0.8 mm**) from the throat plate.
2. The unloaded wheel 4 should have about **0.3 mm** height clearance.

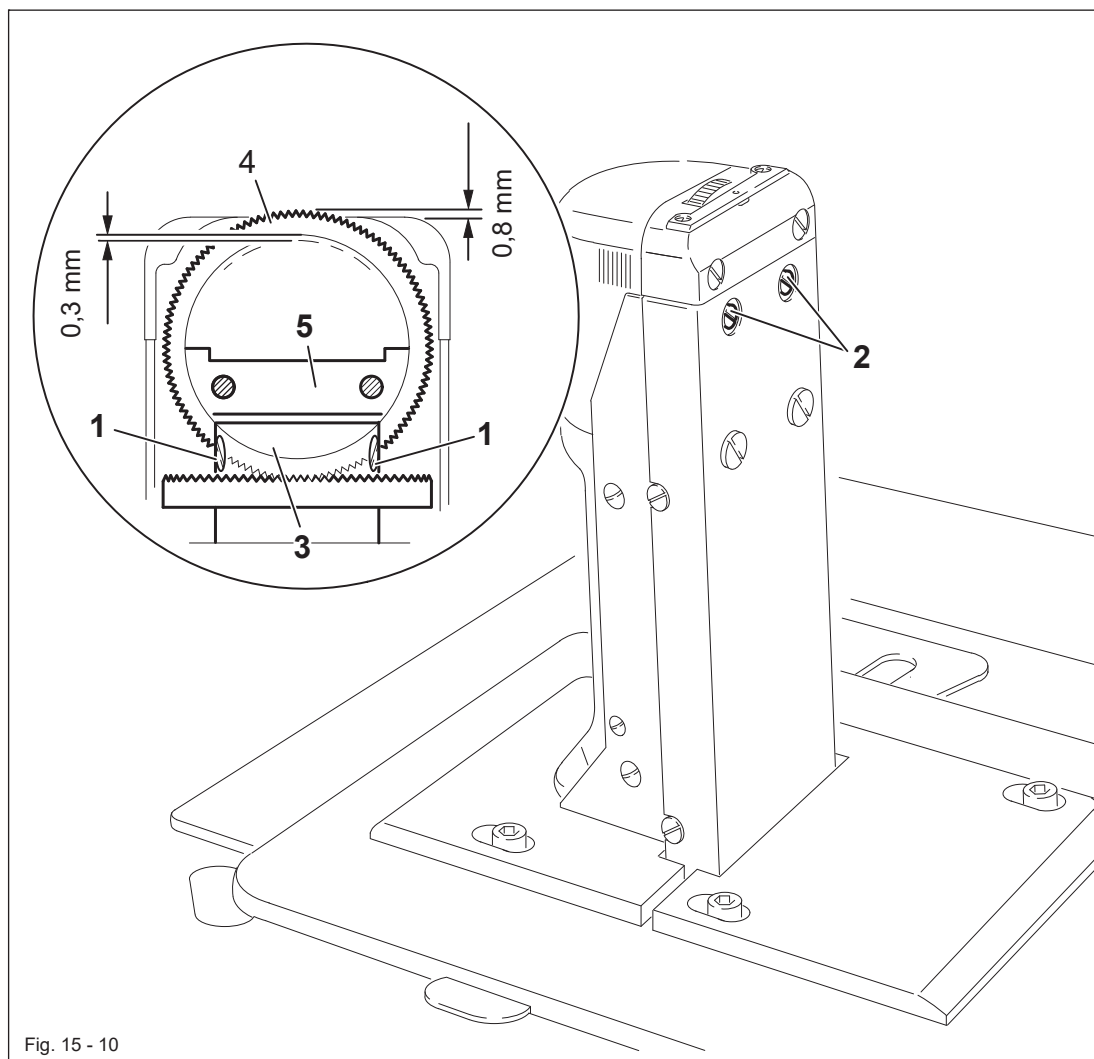
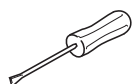

Fig. 15 - 10



- ➡ Swing out the roller presser.
- ➡ Loosen screws **1** and **2**.
- ➡ Move drive wheel **3** according to rule **1**, making sure that the teeth of drive wheel **3** and drive wheel **4** mesh correctly.
- ➡ Tighten screws **1**.
- ➡ Move guide **5** of rule **2** accordingly and tighten screws **2**.

Adjustment

15.04.10a Height of the feed wheel (on the PFAFF 1574)

Requirement

1. The loaded sliding wheel 4 should protrude by tooth height (about **0.8 mm**) from the throat plate.
2. The unloaded wheel 4 should have about **0.3 mm** height clearance.

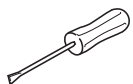
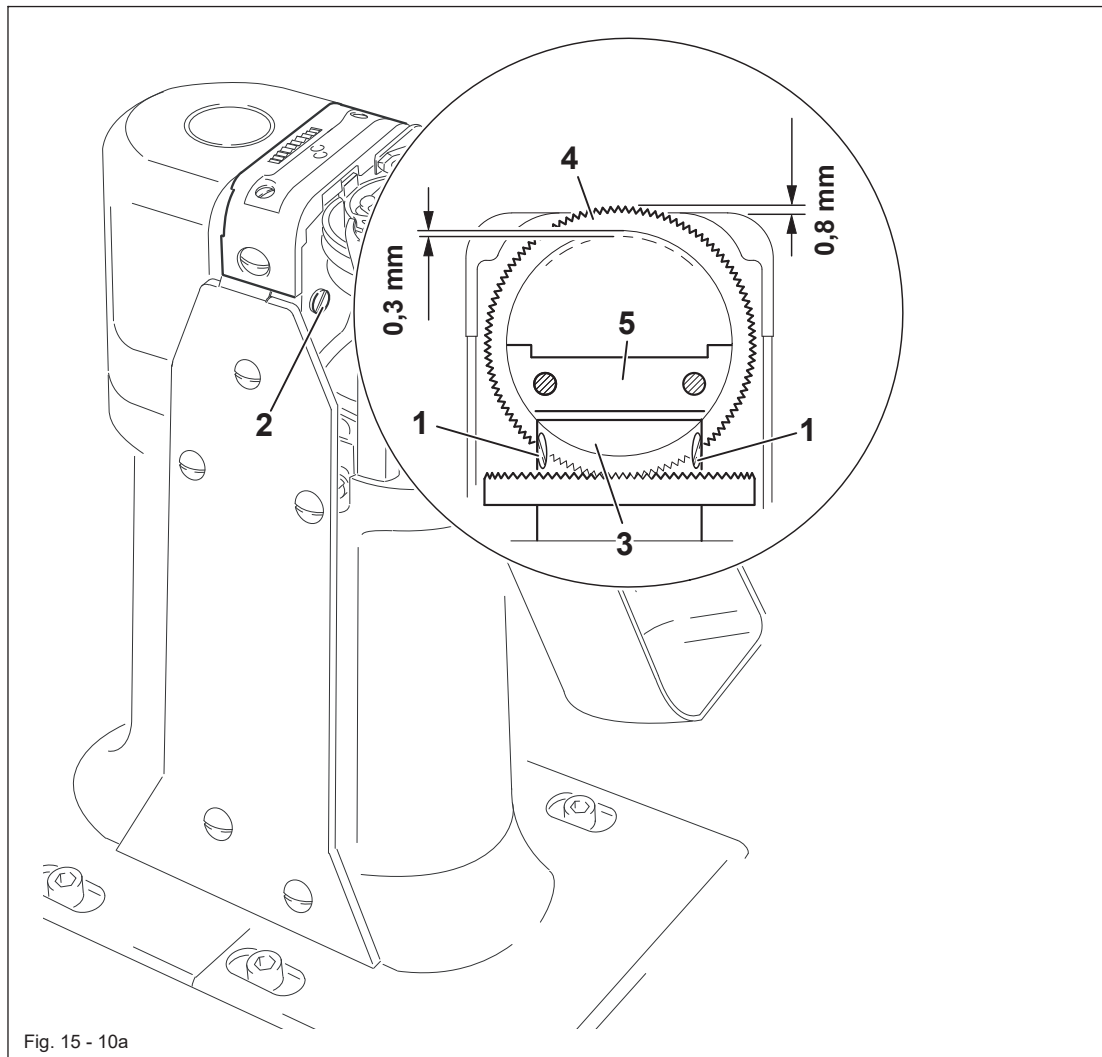

- ➡ Swing out the roller presser.
- ➡ Loosen screws 1 and 2.
- ➡ Move drive wheel 3 according to rule 1, making sure that the teeth of drive wheel 3 and drive wheel 4 mesh correctly.
- ➡ Tighten screws 1.
- ➡ Move guide 5 of rule 2 accordingly and tighten screws 2.

15.04.11 Height of the feed wheel (on the PFAFF 1591 and 1593)

Requirement

The feed wheel should protrude from the needle plate by tooth height (approx. **0.8 mm**)

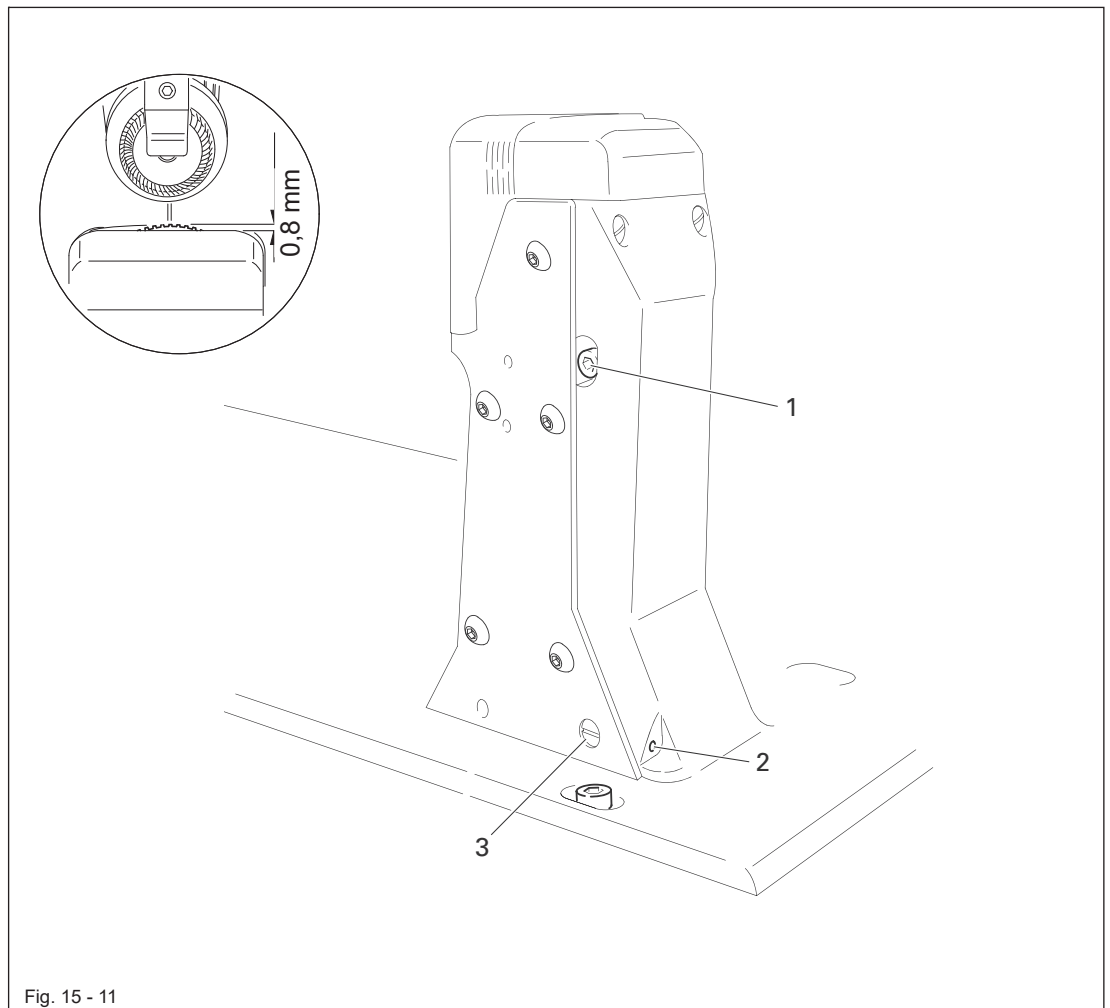
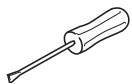

Fig. 15 - 11



- Swing out the roller presser.
- Loosen screws **1**.
- Adjust eccentric **3** (fastening screw accessible through hole **2**) according to the requirement.
- Tighten screws **1**.

Adjustment

15.04.12 Clearance between roller presser and feed wheel

Requirement

With lever **1** raised the clearance between the roller presser and the feed wheel must be **7 mm**.

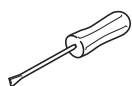
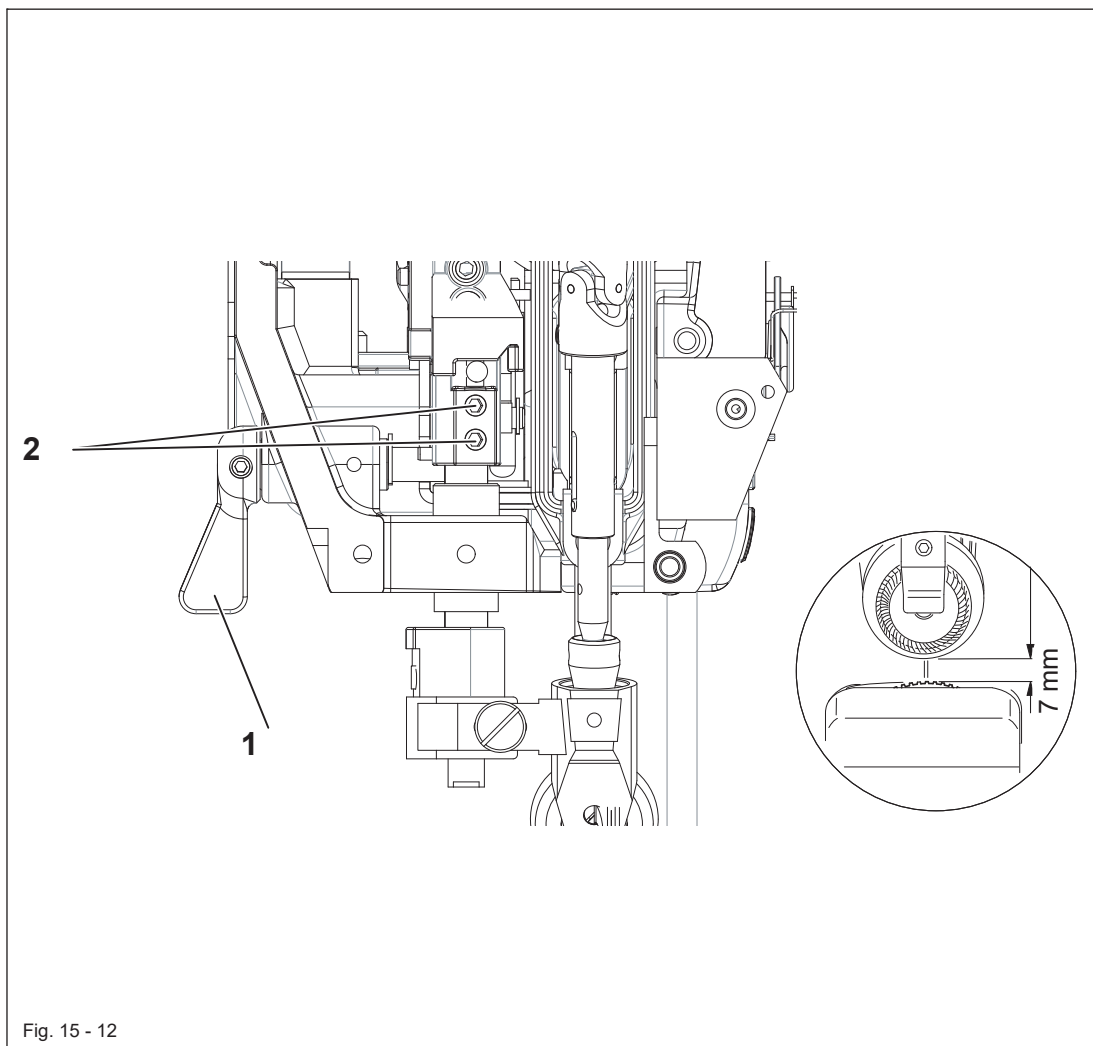

- ➡ Raise lever **1**.
- ➡ Move the presser foot bar (screws **2**) in accordance with the requirement. Take care to ensure that the roller presser is parallel to the feed wheel.

15.04.13 Roller-presser

Requirement

When the roller-presser **1** is resting on the feed wheel **5** it must

1. be parallel to the feed wheel **5** when viewed in the direction of sewing,
2. be in the middle of the needle when viewed crosswise to the direction of sewing and
3. be as close as possible to the (left) needle when viewed in the direction of sewing.

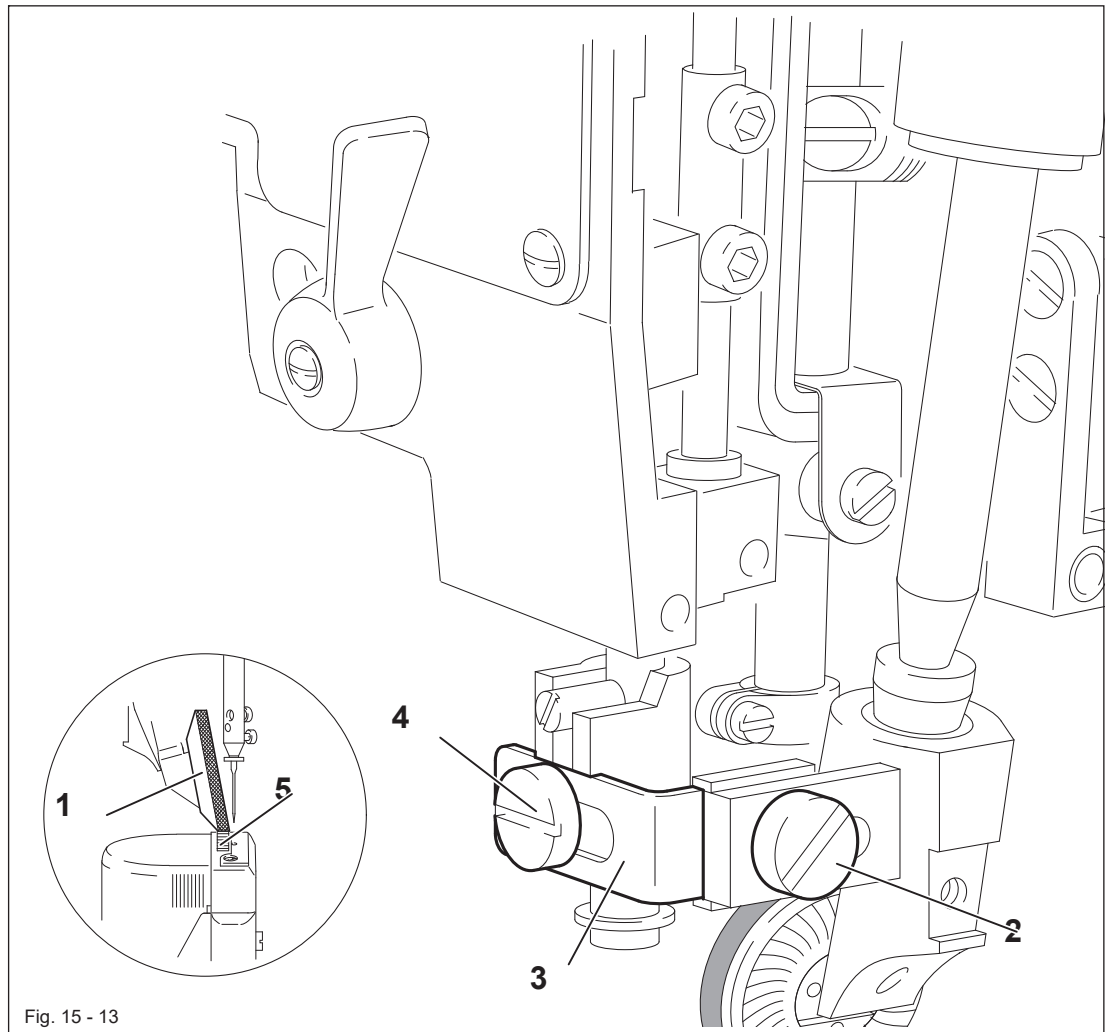
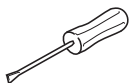

Fig. 15 - 13



- ➡ Raise the roller-presser **1**.
- ➡ Always observe requirement **1** when carrying out the following adjustments.
- ➡ Move the roller-presser **1** (screw **2**) in accordance with requirement **2**.
- ➡ Rollfuß **1** auf das Schiebrad **5** aufsetzen lassen.
- ➡ Move the roller-presser bracket **3** (screw **4**) in accordance with requirement **3**.



When sewing very tight curves the roller-presser **1** should be moved toward the operator slightly.

Adjustment

15.04.13a Hold-down device (only with PFAFF 1574)

Requirement

The hold-down 1 should

1. seen in the sewing direction as close as possible to the needle and
2. Stand in the middle of the needle, seen across the sewing direction.
3. When the roller presser is seated, the distance between the hold-down device 1 and the sewing material 0.2 - 0.3 mm.

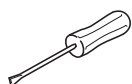
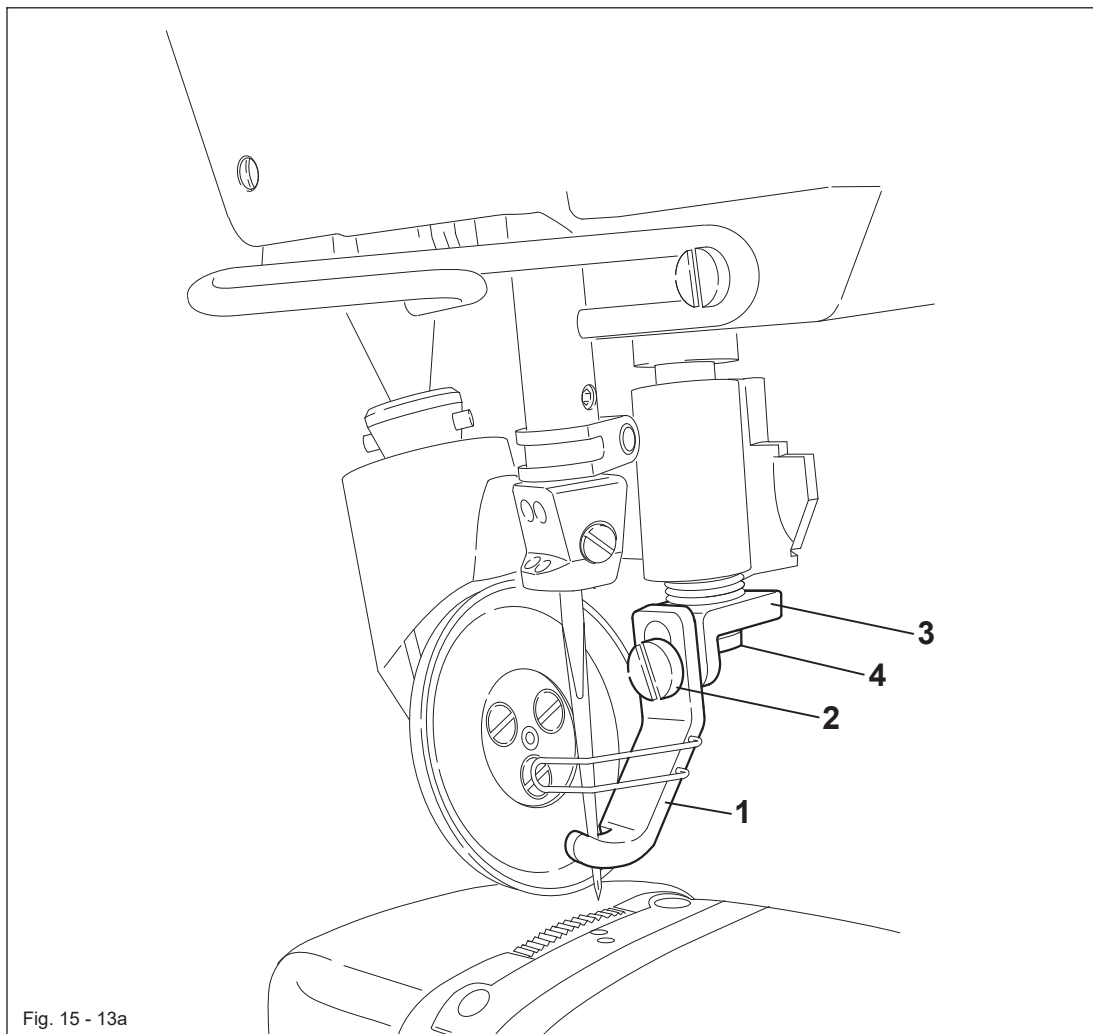

- ➡ Move hold-down device 1 (screw 2) according to **requirement 3**.
- ➡ Move bracket 3 (screw 4) according to **requirement 1 and 2**

15.04.14 Automatic presser-foot lifter

Requirement

When magnet **1** is activated, the roller presser should have a height of **12 mm**!

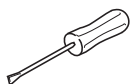
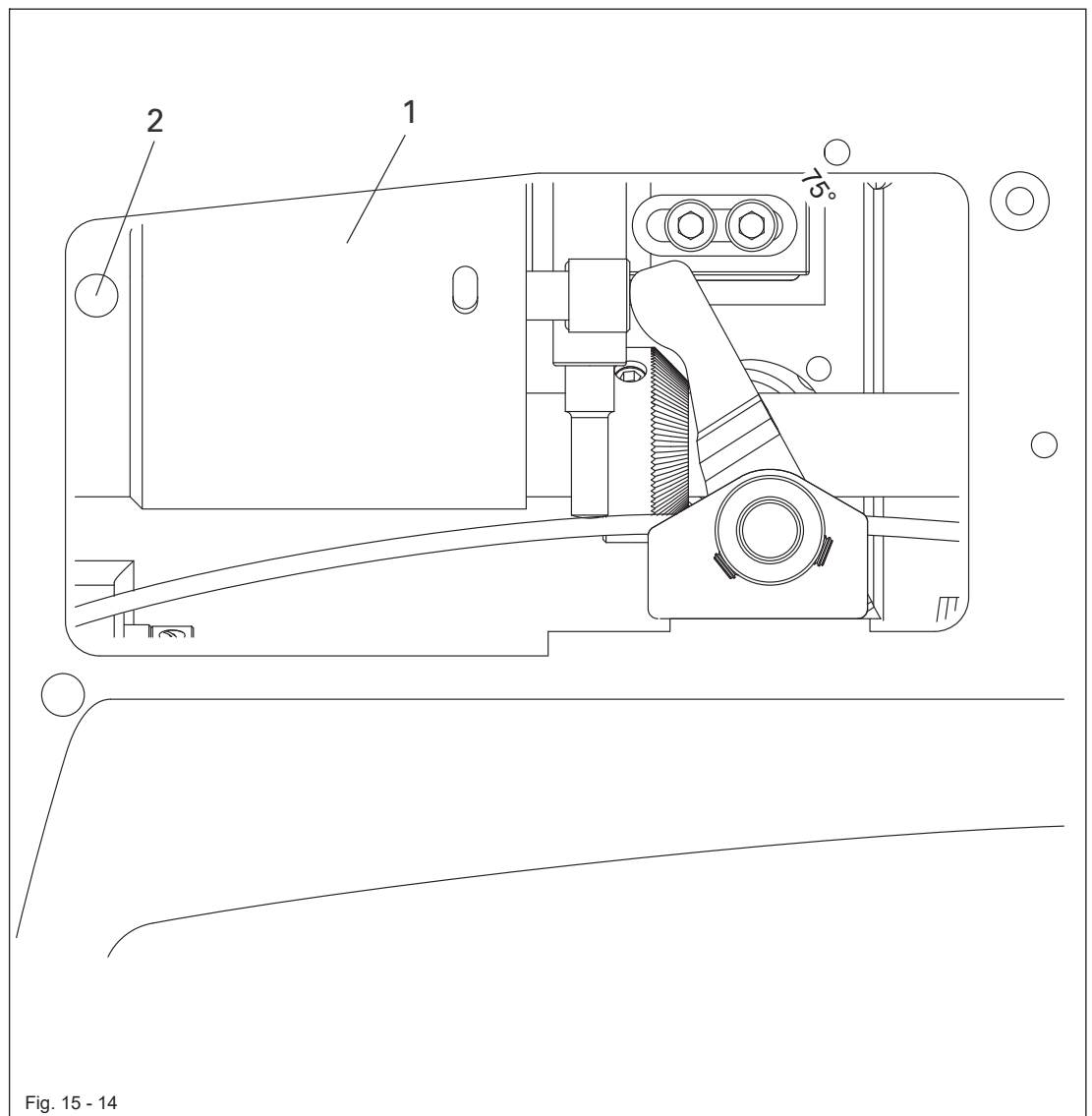

- ➡ Move solenoid **1** (screws **2**) in accordance with the requirement.
- ➡ Turn the machine on and check the requirement.
- ➡ Turn the machine off.



Depending on the thickness of the material, the clearance between the roller-presser and the feed wheel can be increased to a maximum of **12 mm** by moving the solenoid **1** to the right.

Adjustment

15.04.15 Knee lever

Requirement

1. The knee lever must have a little play before the roller-presser is raised.
2. The lever for the roller-presser must drop automatically when the knee lever is pressed as far as it will go.
3. Bar 5 of the knee lever must be at an angle of approx. 75° to the bedplate.

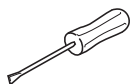
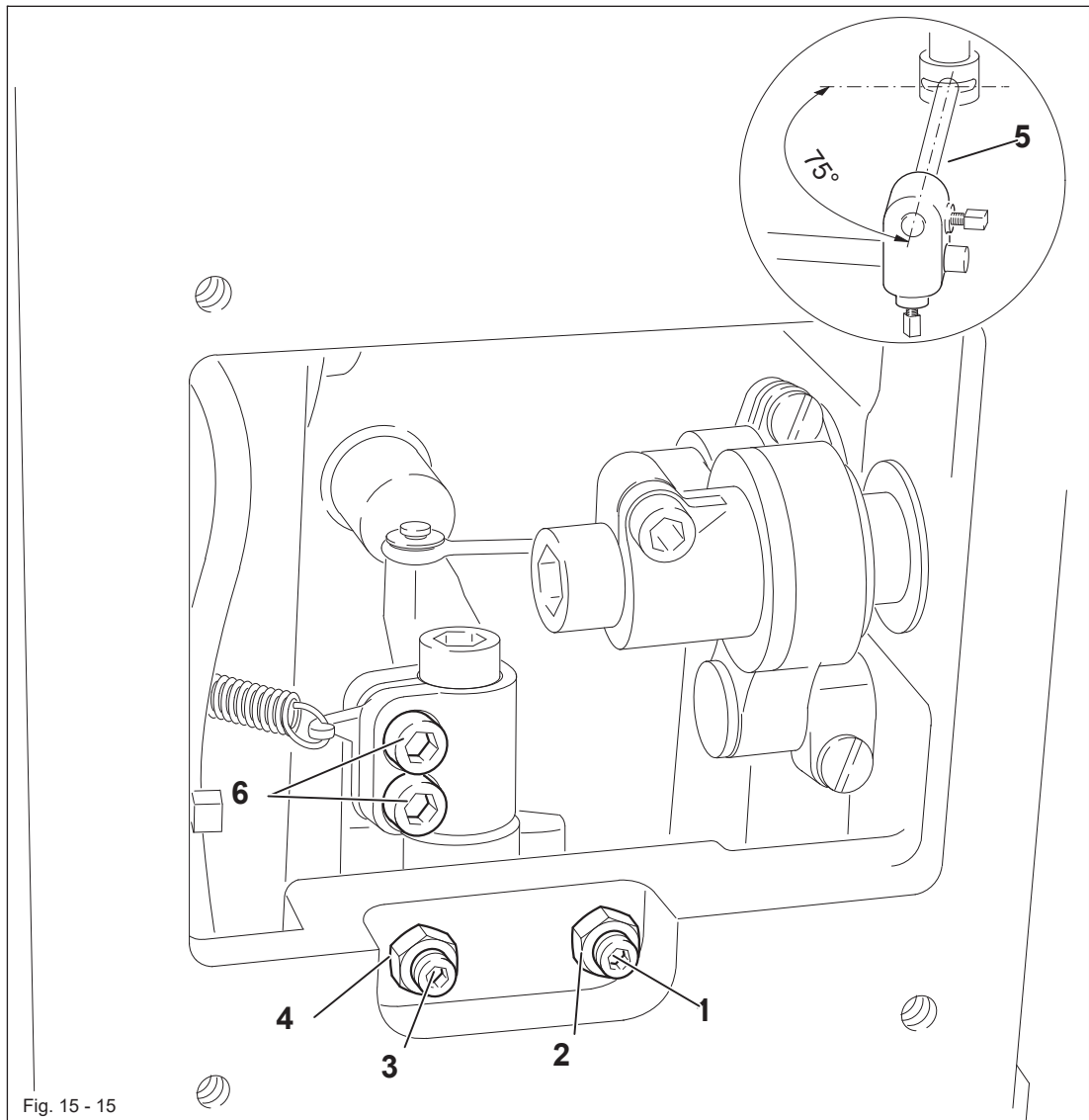

- ➡ Turn screw 1 (nut 2) in accordance with requirement 1.
- ➡ Turn screw 3 (nut 4) in accordance with requirement 2.
- ➡ Adjust bar 5 (screw 6) in accordance with requirement 3.

15.04.16 Tension release

Requirement

6 should be at least **0.5 mm** apart

1. when lever **1** is raised,
2. when solenoid **4** is pressed.

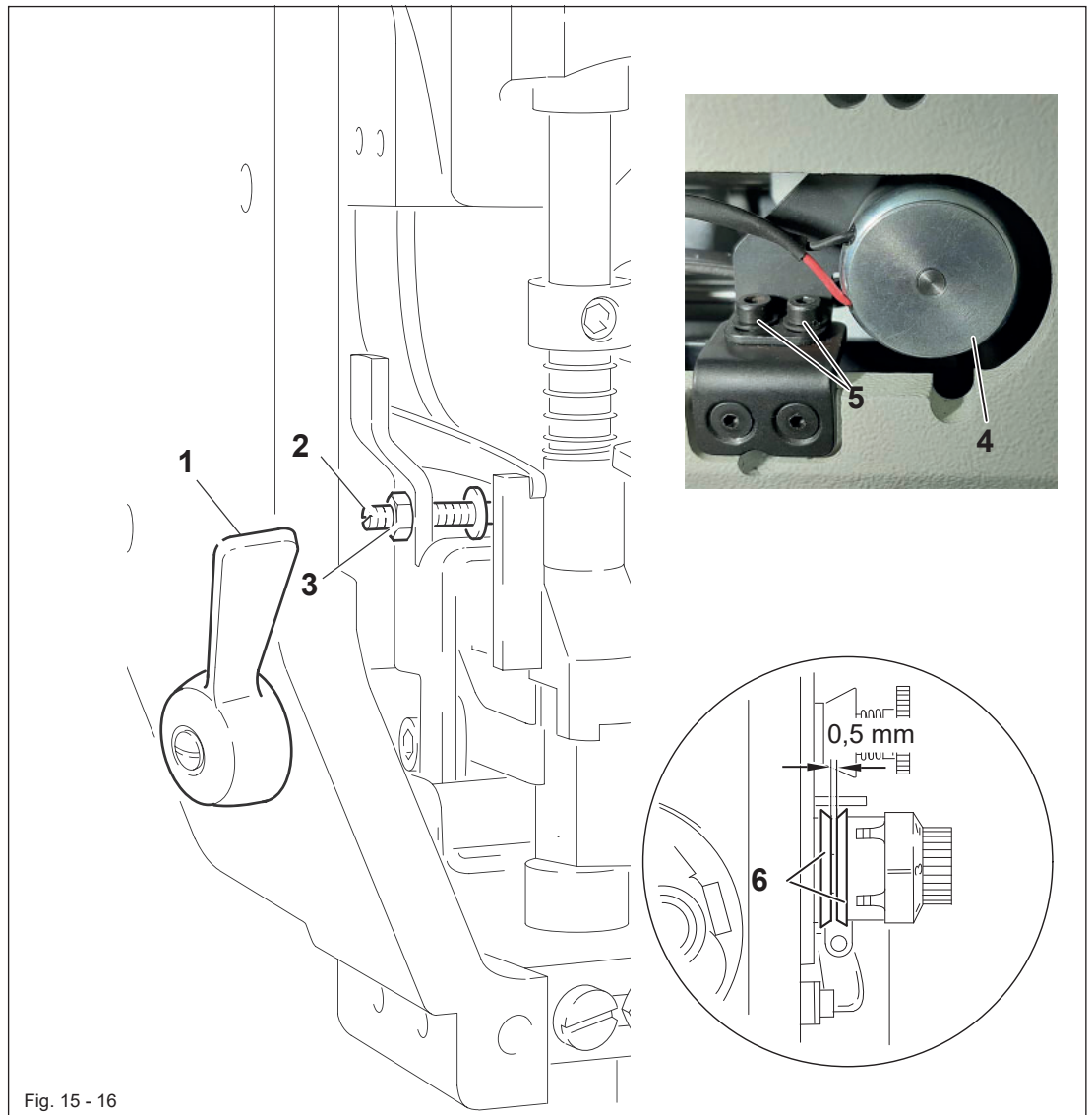
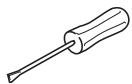

Fig. 15 - 16



- ➡ Raise lever **1** and adjust screw **2** (nut **3**) in accordance with requirement **1**.
- ➡ Press solenoid **4** as far as possible.
- ➡ Adjust solenoid **4** (screws **5**) in accordance with requirement **2**.



The point of time when the tensioned is released by solenoids **4** can be set with the service functions, see **Chapter 15.07 Parameter settings**.

15.04.17 Thread check spring (on the PFAFF 1571; 1591 and 1593)

Requirement

1. The movement of thread check spring **3** should be completed when the needle point penetrates the fabric (spring stroke approx. **7 mm**).
2. When the largest thread loop is formed while the thread is passed around the hook, the thread check spring **3** should rise slightly from its support **1**.

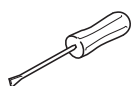
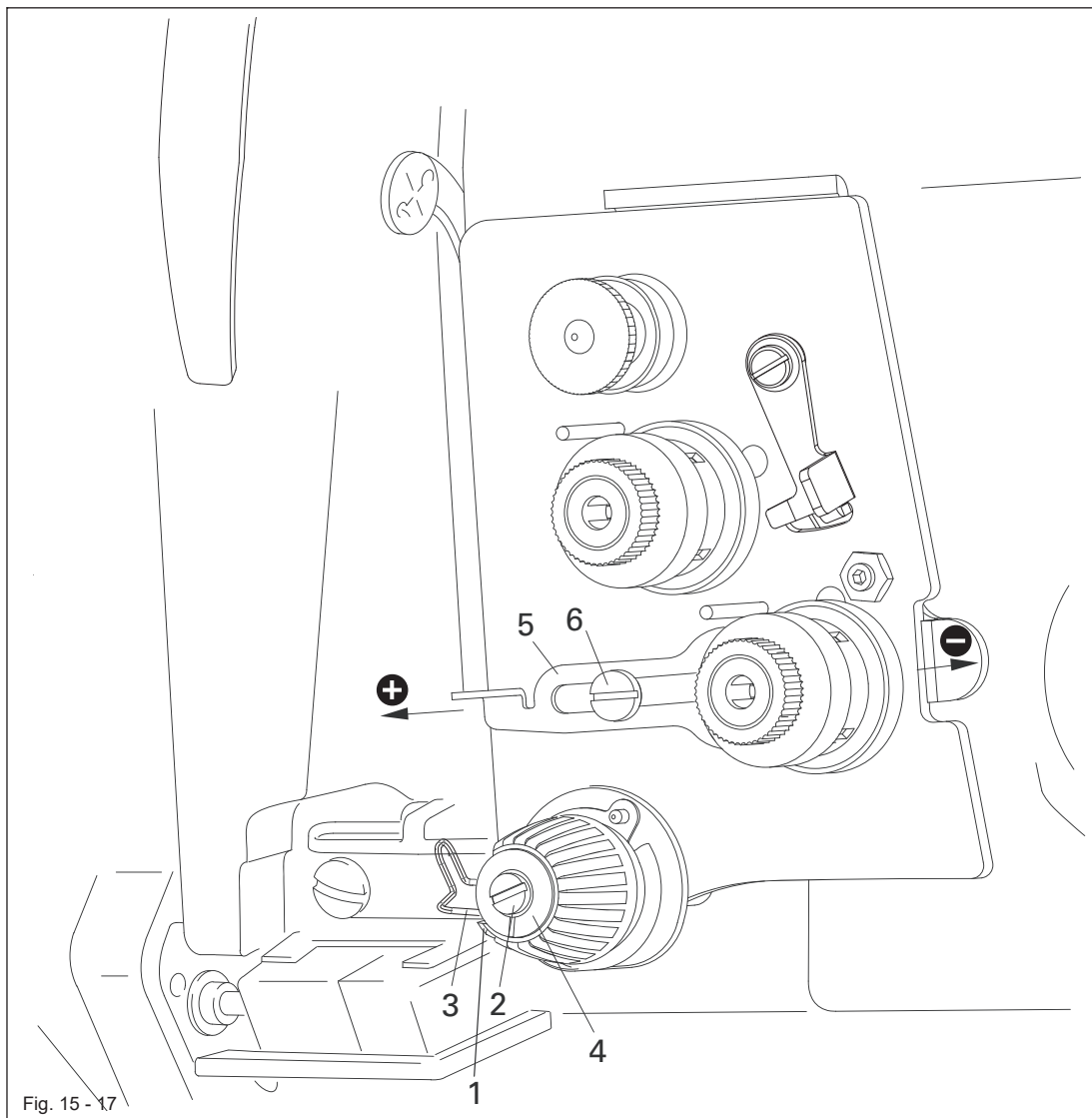

- ➡ Adjust support **1** (screw **2**) according to requirement **1**.
- ➡ Turn the thread tension spring **3** and sleeve **4** (screw **2**) to adjust the spring force.
- ➡ Adjust the thread regulator **5** (screw **6**) according to requirement **2**.



For technical reasons it may be necessary to deviate from the specified springstroke or spring tension. Move the thread regulator **5** (screw **6**) towards "+" (= more thread) or "-" (= less thread).

15.04.17a Thread check spring (on the PFAFF 1574)

Requirement

1. The movement of the thread check spring 3 should be finished when the needle points puncture the material (spring deflection approx. 7 mm).
2. The thread check spring 3 should lift slightly off the support 1 when forming the maximum thread loops while passing the thread around the hook.

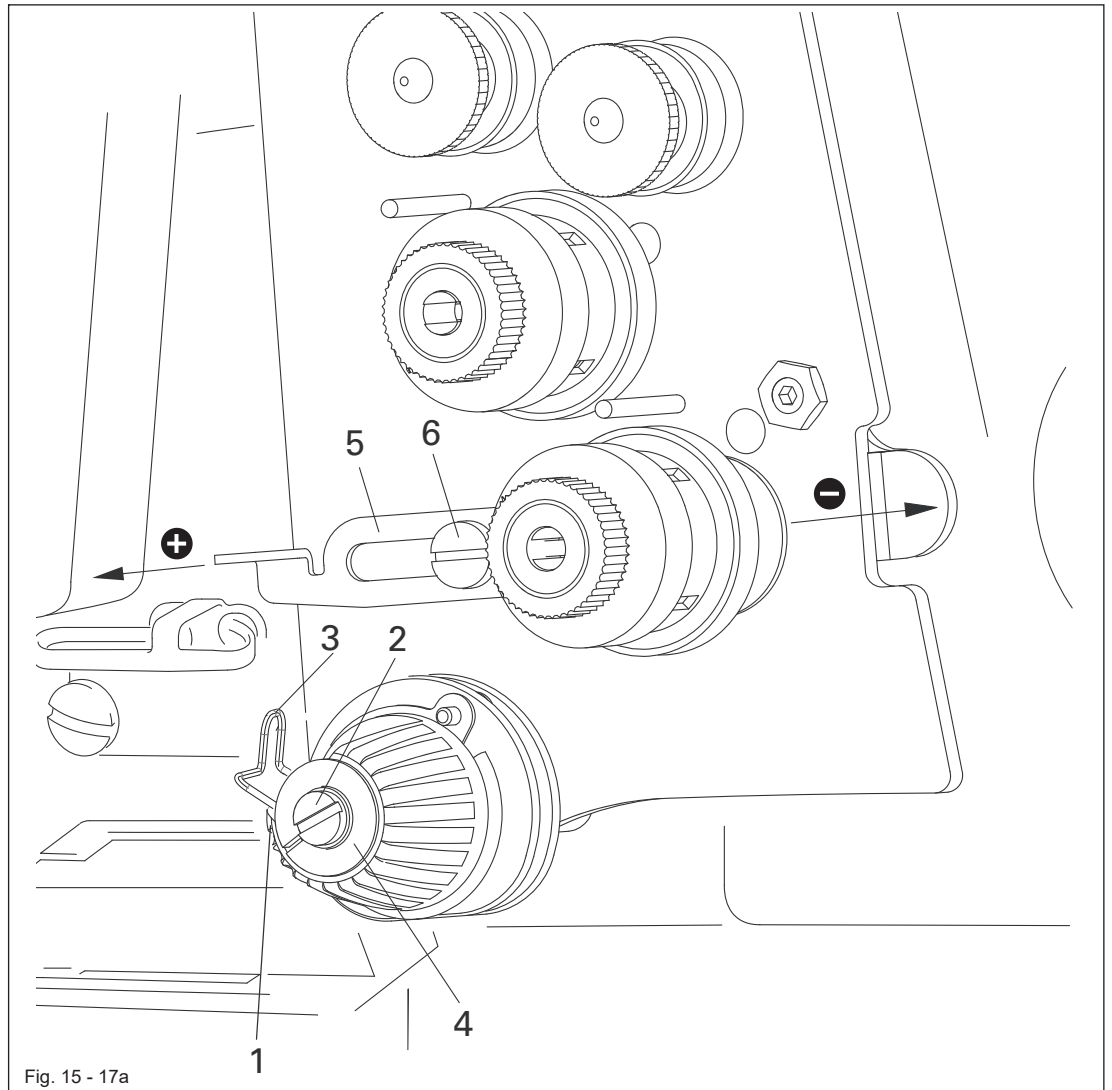
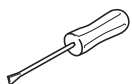

Fig. 15 - 17a



- Adjust the support 1 (screw 2) according to requirement 1.
- Turn the sleeve 4 (screw 2) to set the spring tension of the thread check spring 3.
- Adjust the slack thread regulator 5 (screw 6) according to requirement 2.



It may be necessary to deviate from the specified spring deflection or spring tension for reasons relating to the sewing technology. Adjust the slack thread regulator 5 (screw 6) by "+" (= more thread) or "-" (= less thread).

Requirement

1. The tension magnet stroke should be **0.9 mm** in the starting position.
2. Adjust the carrier plate in parallel approx. **15 mm** on the two nuts **3** so that there is approx. **0.05 - 0.1 mm** air between the pressed magnetic plate.

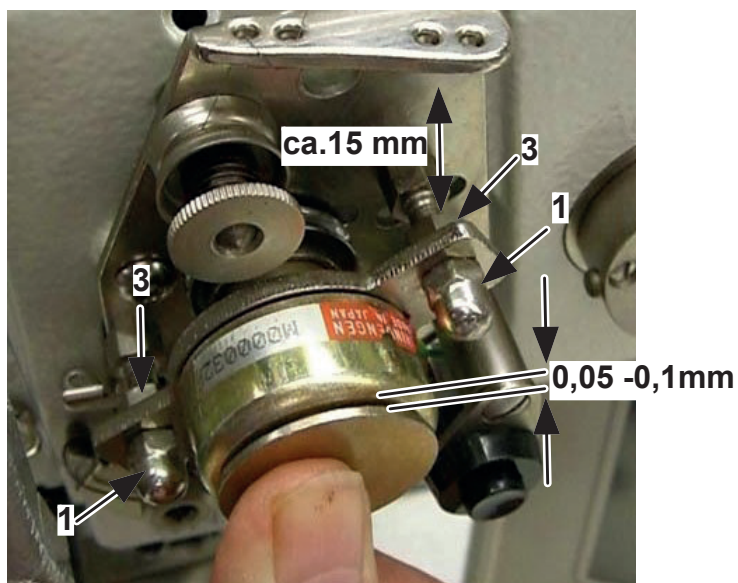
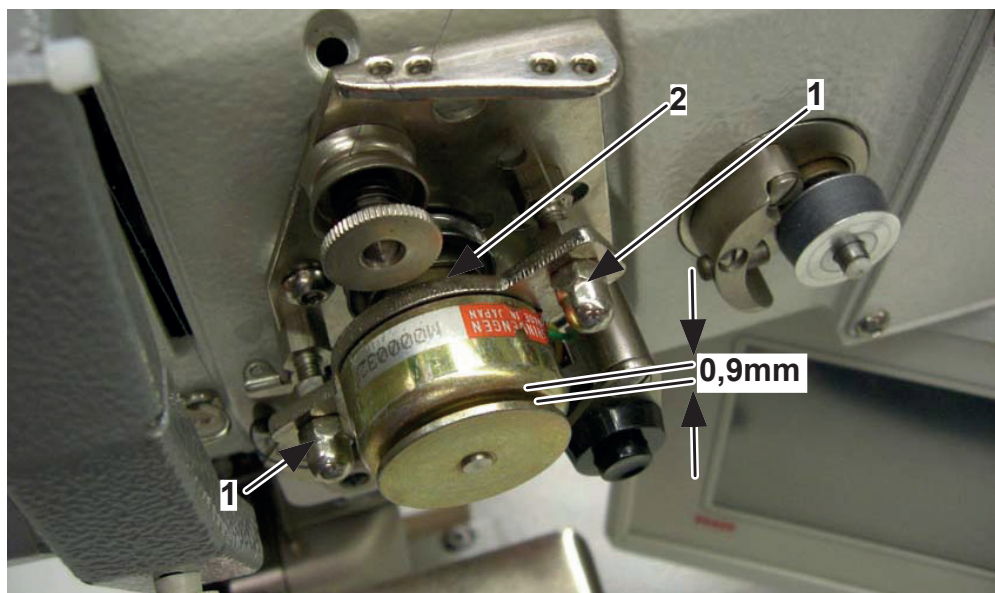
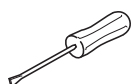

Fig. 15-18



- ➡ Turn off the machine.
- ➡ Remove both cap nuts **1** and remove the magnet. Set the tension magnet stroke according to **requirement 1** using the two lock nuts **2**.
- ➡ Screw the magnet slightly over the two cap nuts **1**.
- ➡ Press the magnetic plate by hand (tension discs closed), adjust according to **requirement 2**.
- ➡ Tighten the magnet over the two cap nuts **1**.



The tension discs must not be too polished. The voltage value should not be over **50** in manual operation.

15.04.19 Bobbin winder

Requirements

1. When the bobbin winder is engaged, the winding spindle must be driven reliably. When the bobbin winder is disengaged, the friction wheel **5** must not be moved by drive wheel **1**.
2. The bobbin winder must switch itself off, when the filled thread is about **1 mm** from the edge of the bobbin.

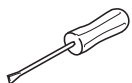
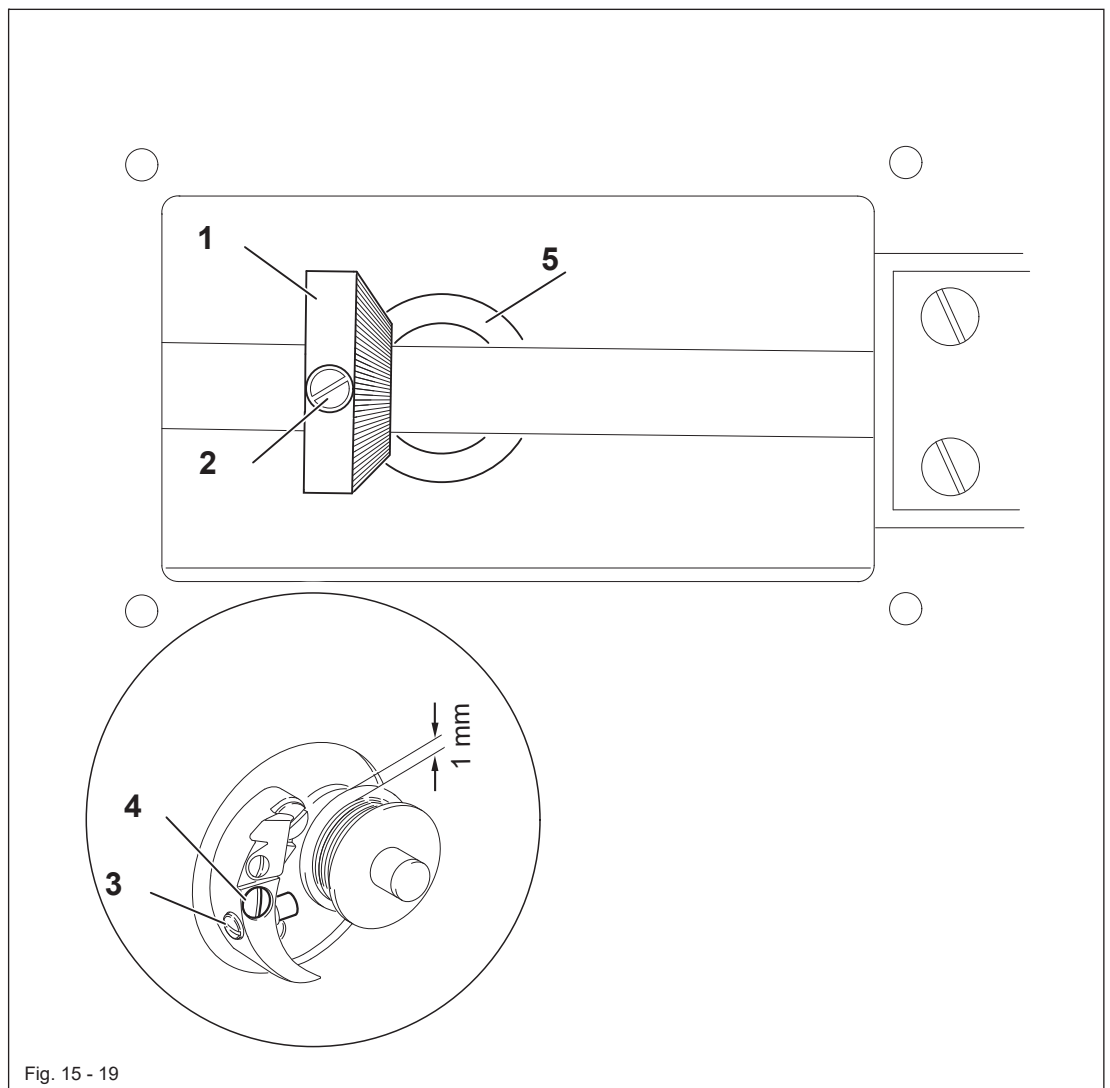

- ➡ Position drive wheel **1** (screws **2**) according to requirement **1**.
- ➡ Position bolt **3** (screw **4**) according to requirement **2**.

15.04.20 Roller-presser pressure

Regel

The material must be fed reliably. No pressure marks may be made on the material.

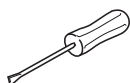
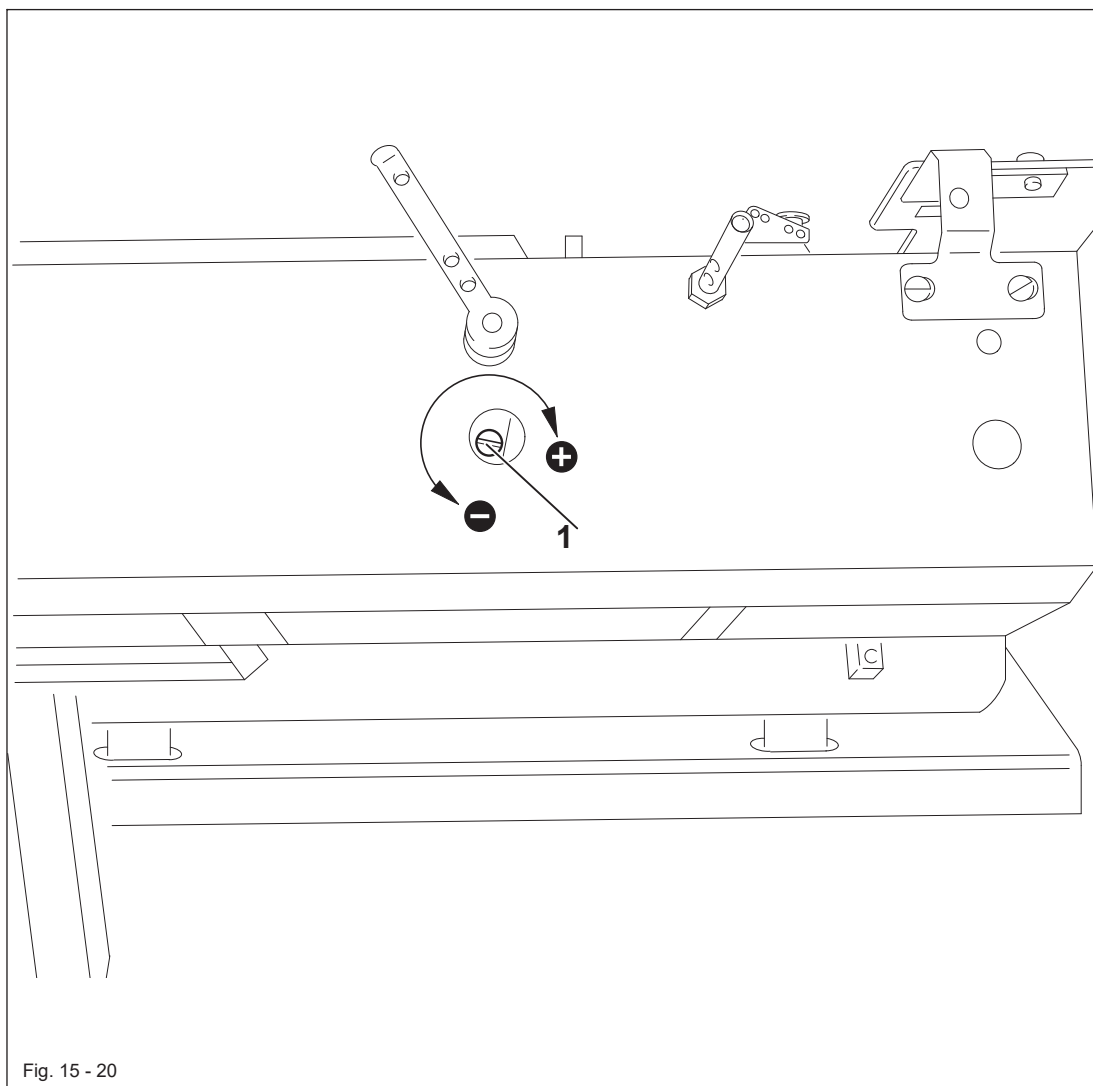

➡ Adjust the presser foot pressure with screw **1** in accordance with the **requirement**.



Screw **1** is located under a cover.



If the presser foot pressure is low, the lowering speed of the presser foot can be increased with parameter „202“, see **Chapter 15.07 Parameter settings**.

15.04.21 Lubrication

Requirement

After a running time of **10** seconds a fine line of oil should form on a strip of paper held next to the hook.

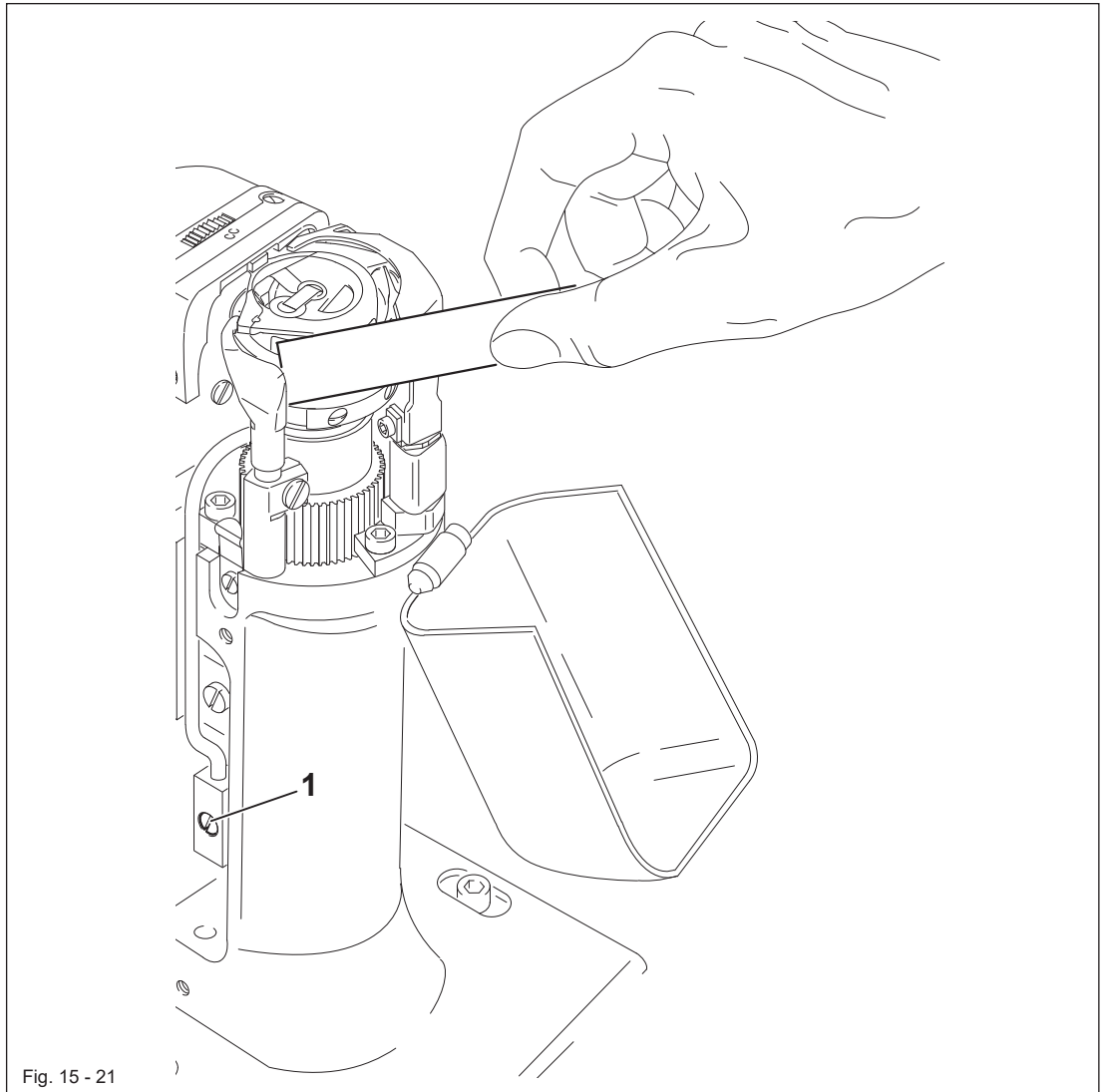
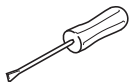

Fig. 15 - 21



- Check whether oil has been filled in and that there is no air in the oil lines.
- Let the machine run for **2-3** min.



While the machine is running do not place hands in the needle or hook area! Danger of injury from moving parts!

- With the machine running hold a strip of paper on the hook and check the requirement..
- If necessary, adjust the oil flow on screw **1**.

Adjustment

15.04.22 Re-engage safety coupling



The coupling **1** is set by the manufacturer. When the thread jams, the coupling **1** disengages in order to avoid damage to the hooks. A description of how to engage the coupling **1** follows.

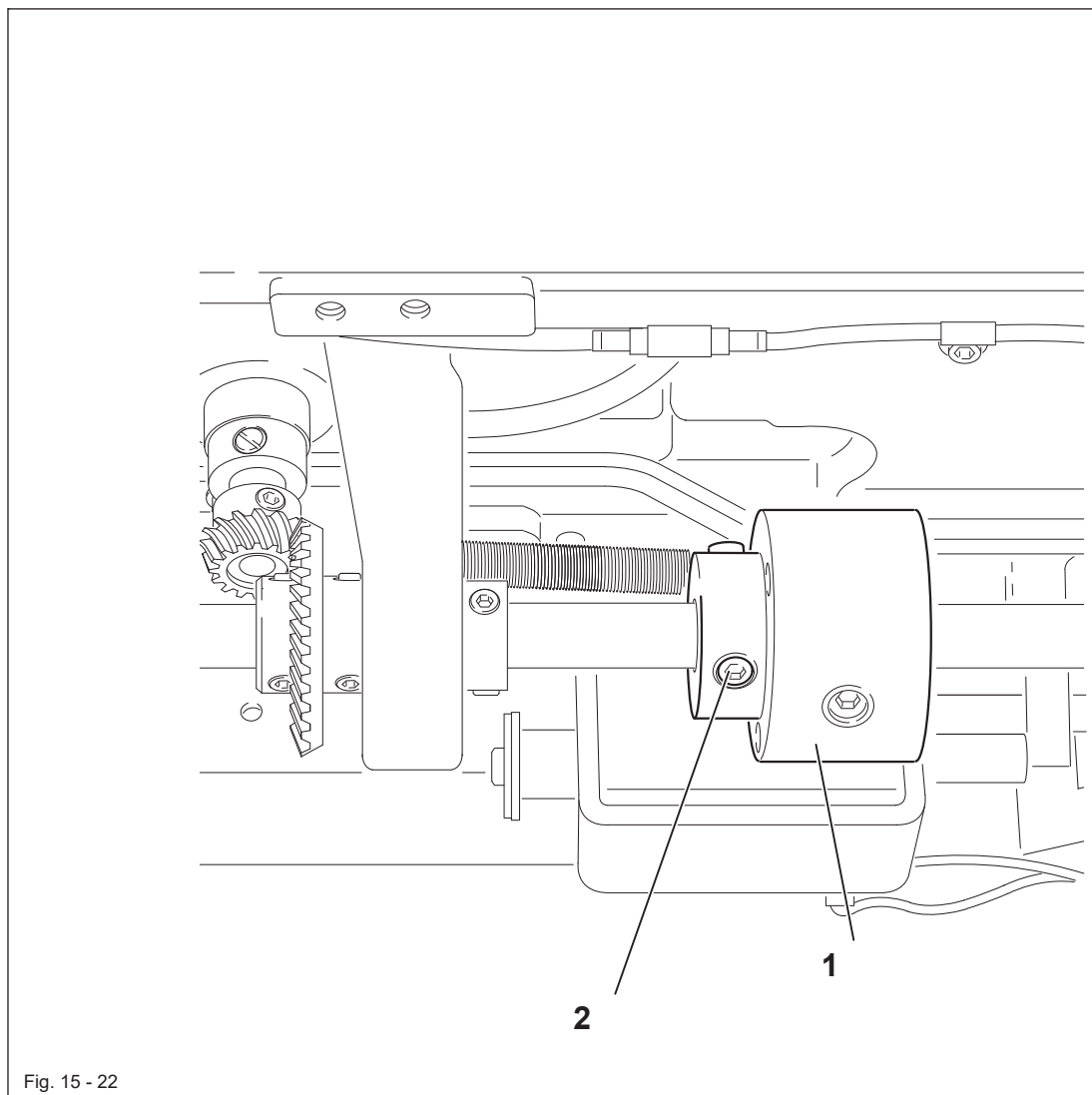
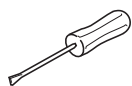

Fig. 15 - 22



- ➡ Remove jammed thread.
- ➡ Hold coupling **1** with screw **2** and turn the balance wheel, until you feel coupling **1** snap-back into place again.

13.05 Adjust edge trimmer -725/04

13.05.01 Knife carrier position (on the PFAFF 1571)

Rule

When the edge trimmer is switched on and the adjusting wheel 1 is turned until you feel it reach the upper stop,

1. the knife carrier 2 should be parallel to the post and
2. the upper edge of the needle plate should be at the centre of the knife angle.

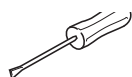
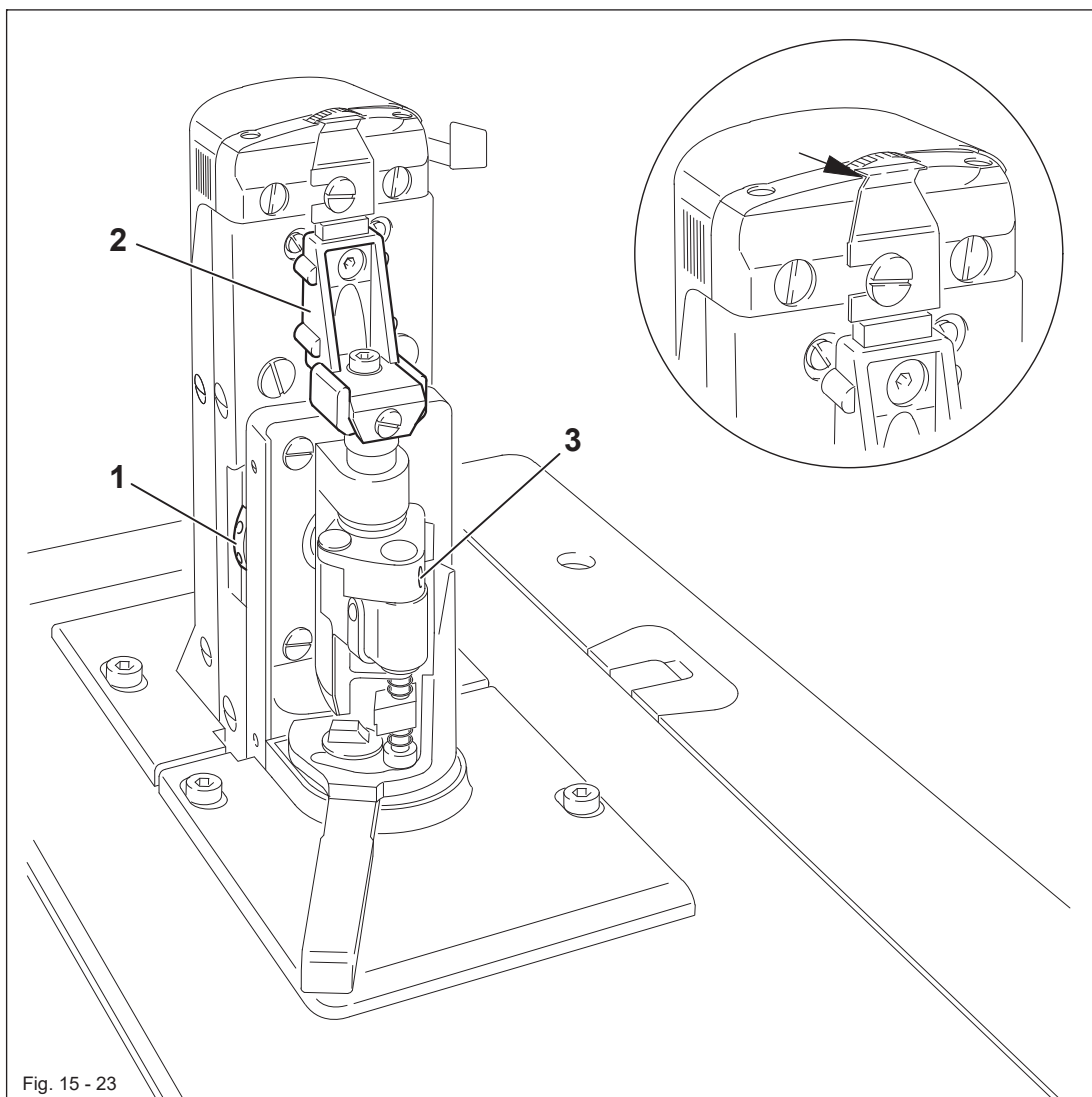

- ➡ Turn the adjusting wheel 1 until you feel it reach the upper stop and switch on the edge trimmer.
- ➡ Adjust the knife carrier 2 (screw 3) according to the **rule**.

15.05.02 Position of the knife holder (on the PFAFF 1574 and 1591)

Requirement

When the thread trimmer is engaged, the centre of the angular knife opening must bevel with the top edge of the needle plate.

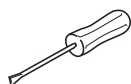
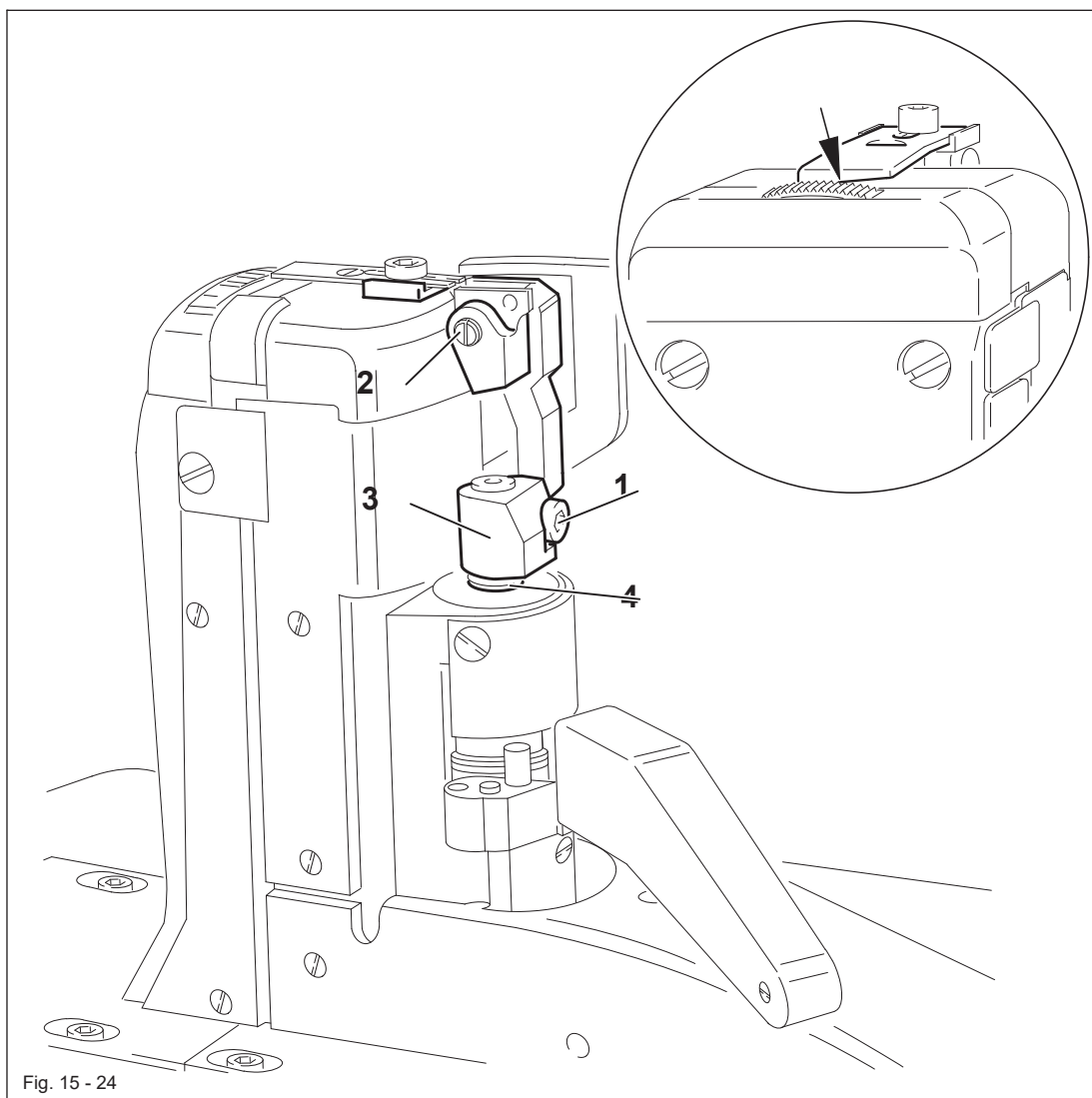

- ➡ Switch off the machine and engage the edge trimmer.
- ➡ Loosen screw 1.
- ➡ By turning eccentric 2, position the knife in the centre of its adjustment range.
- ➡ Adjust knife holder 3 according to the requirement and tighten screw 1.
- ➡ Position locking ring 4 on the knife holder 3.



Depending on the material thickness, changes in the basic setting of eccentric 2 are possible.

15.05.03 Knife stroke (on the PFAFF 1571)

Rule

The knife stroke can be set within a range of 1.0 to 3.5 mm to optimally suit all materials used.

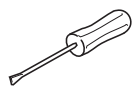
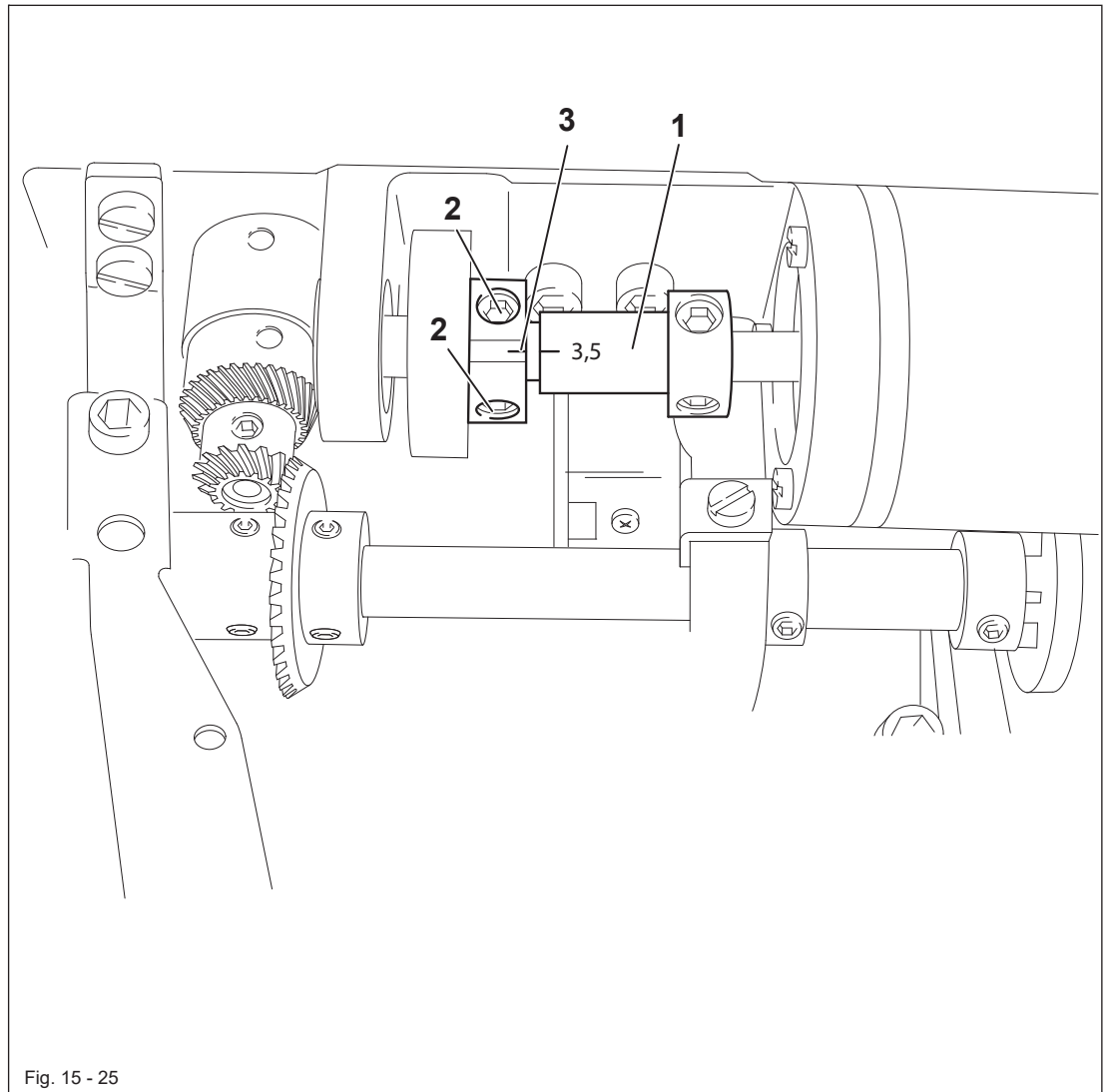

- ➡ Turn the eccentric 1 (screws 2) so that the marking of the desired cutting stroke is opposite the marking on the clamp collar 3.

Adjustment

15.05.04 Knife stroke (on the PFAFF 1574 and 1591)

Requirement

The knife stroke can be adjusted over a range from 2.0 to 3.5 mm, allowing the best possible adaption to all materials used.

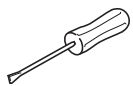
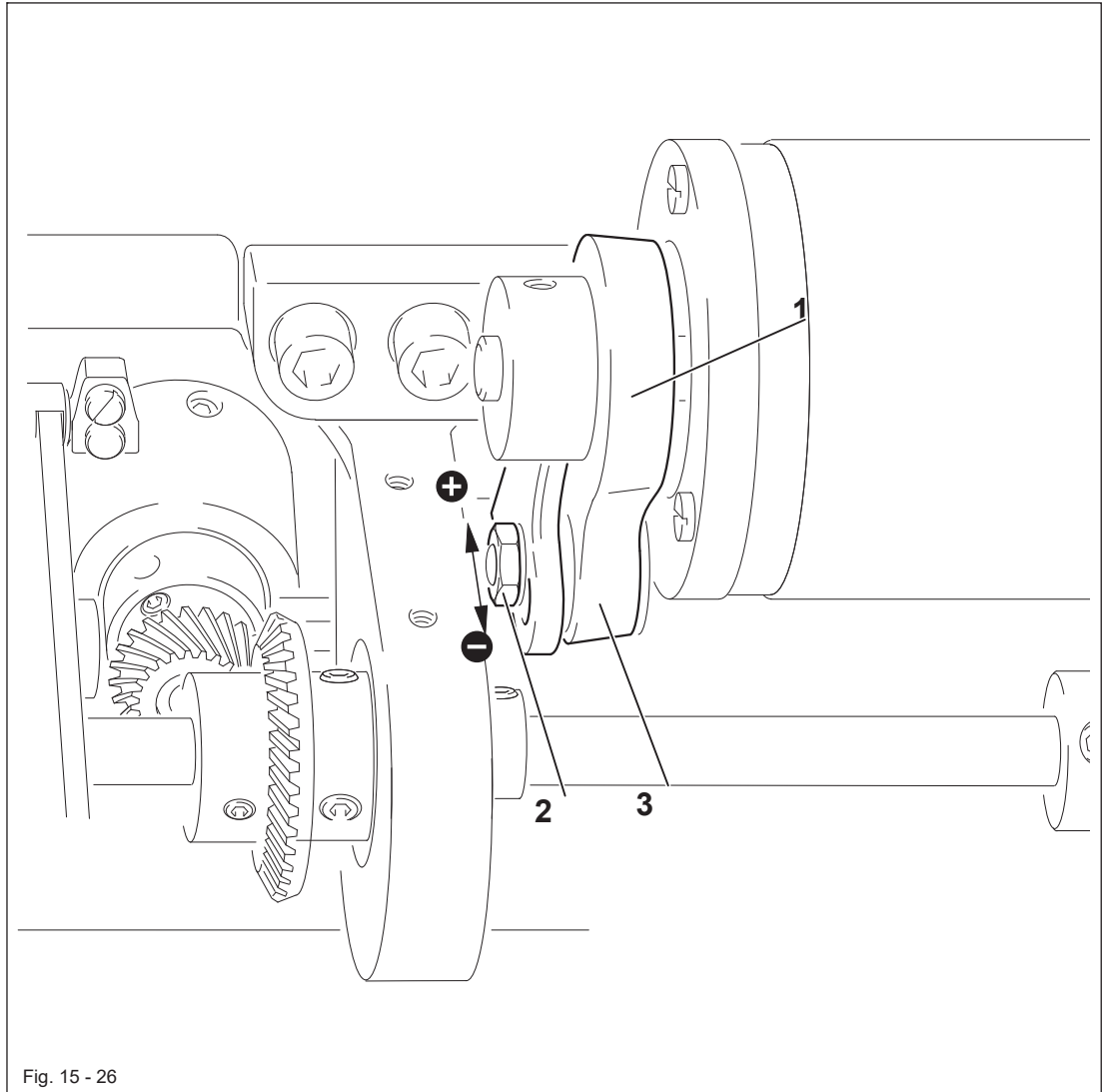

➡ Adjust crank 1 (nut 2) in slotted lever 3 according to the requirement.

15.05.05 Knife movement (on the PFAFF 1571)

Rule

When the edge trimmer is swung in and the needle is in the needle hole, the movement of the knife 1 should be half way in front of and half way behind the needle when turning the motor shaft manually.

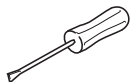
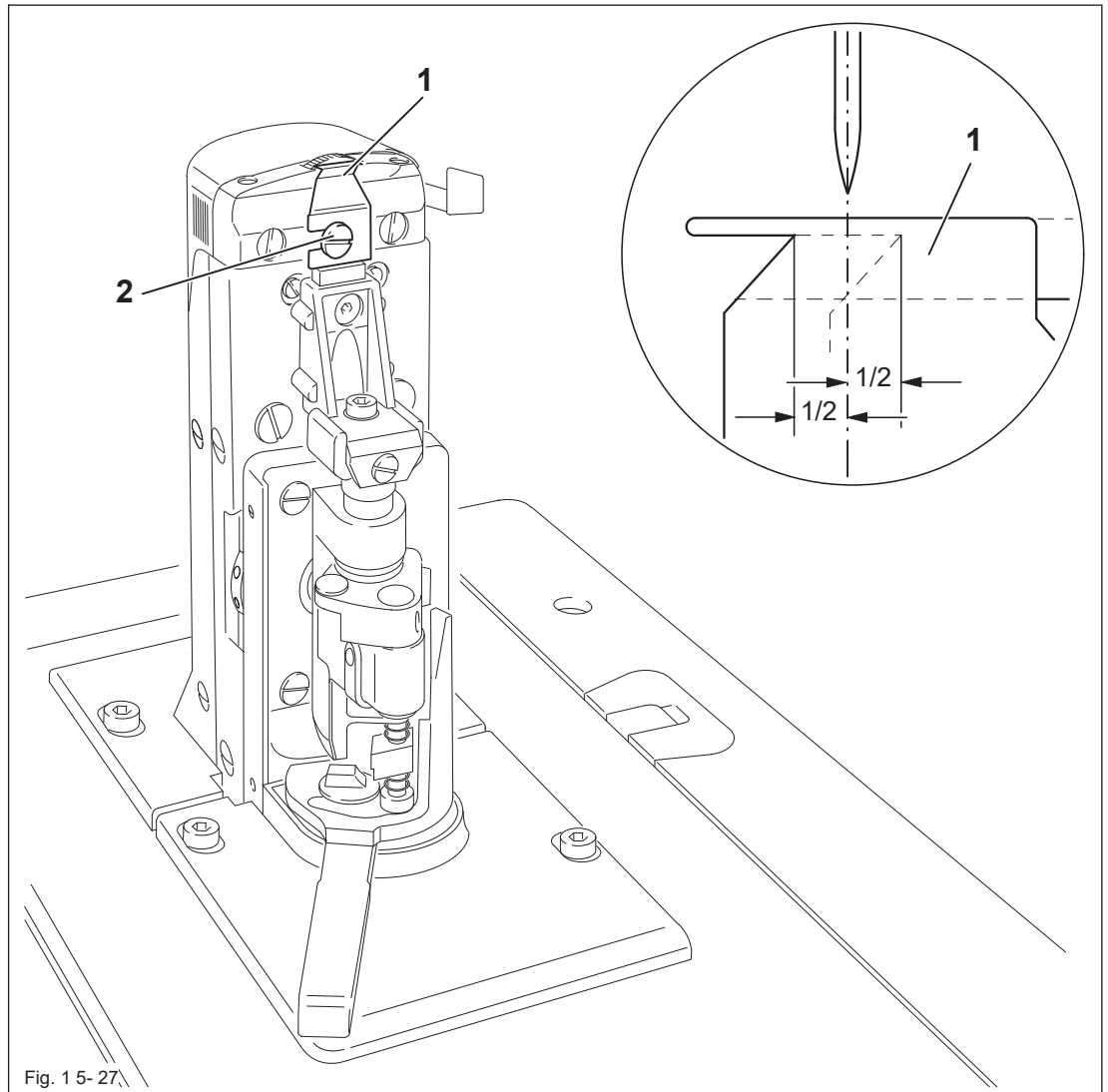

- ➡ Switch off the machine and swing in the edge trimmer.
- ➡ Adjust the knife 1 (screw 2) according to the rule.

Adjustment

15.05.06 Cutting stroke (on the PFAFF 1574 and 1591)

Requirement

When the edge trimmer is engaged and the needle is in the needle hole, the stroke of knife 3 should be half in front of and half behind the needle, when the motor shaft is turned by hand.

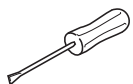
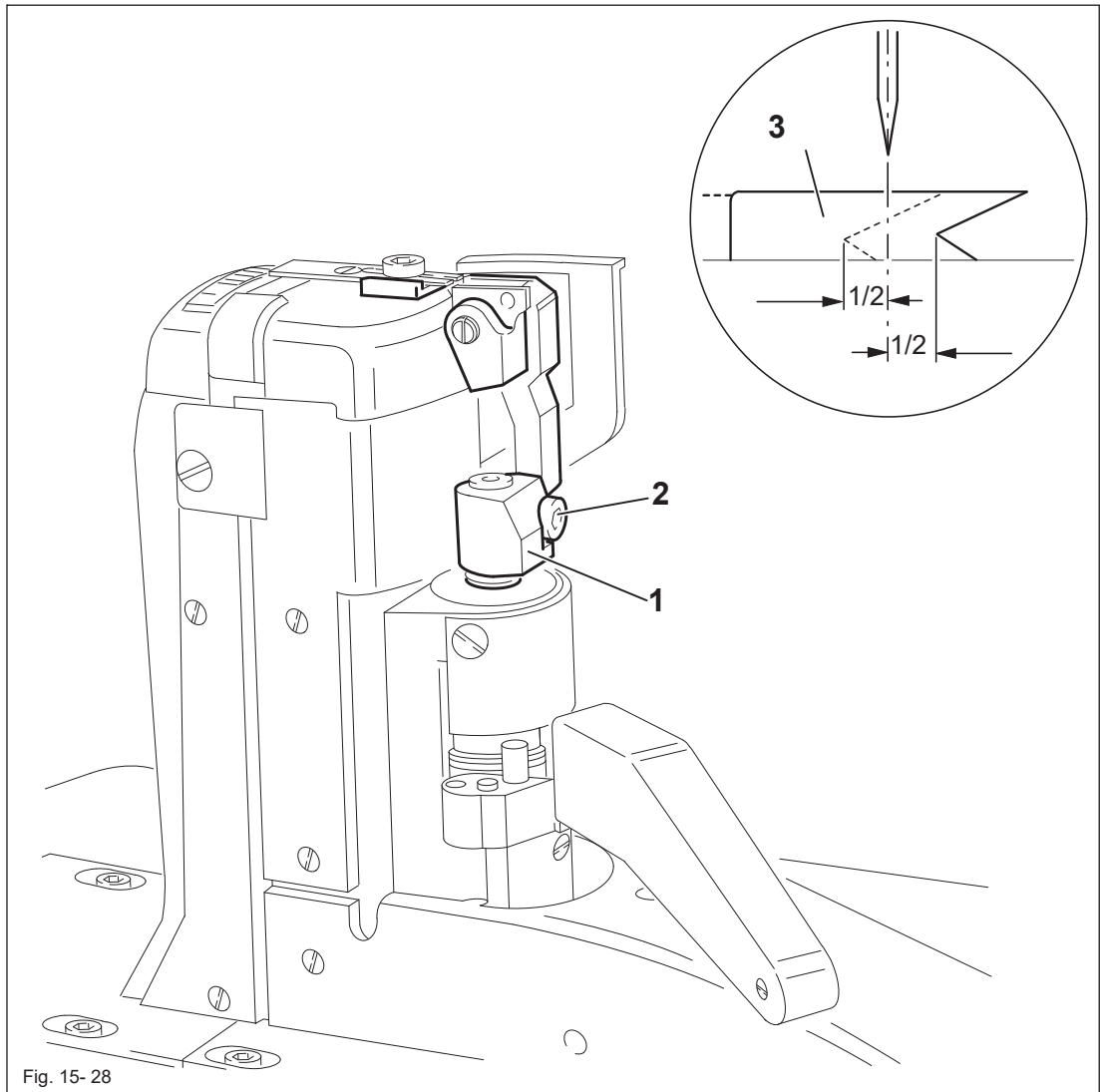

- ➡ Switch off the machine and engage the edge trimmer.
- ➡ Adjust knife holder 1 (screw 2) according to the requirement.

15.05.07 Knife position

Rule

When the edge trimmer is swung in, the knife should touch the needle plate insert lightly, whereby no whistling sound should occur during the trimming.

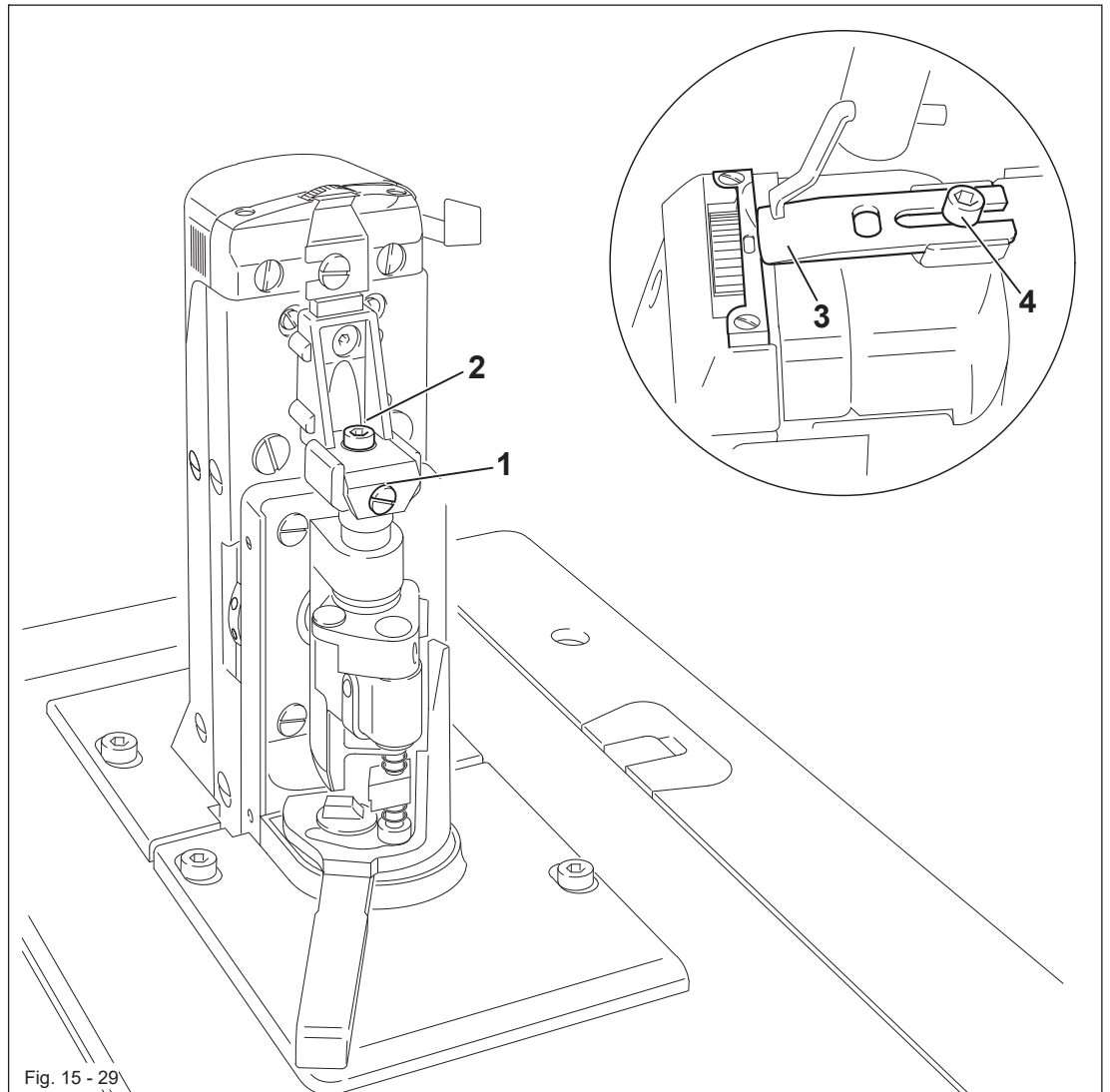
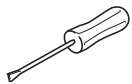

Fig. 15 - 29



PFAFF 1571

- Turn the screw **1** (screw **2**) according to the **rule**.
- Carry out a test cut and maybe repeat the adjustment.

PFAFF 1574 und 1591

- Adjust the knife **3** (screw **4**) according to the **rule**.
- Carry out a test cut and maybe repeat the adjustment.

Adjustment

15.06 Adjusting the thread trimmer -900/81

15.06.01 Resting position of the roller lever / radial position of the control cam

Requirement

1. When the thread trimmer is in its resting position, lever **5** should be touching piston **6** and the roller of roller lever **7** should be **0.3 mm** away from control cam **3**.
2. When the take-up lever is at t.d.c., control cam **3** should just have placed roller lever **7** in its resting position.

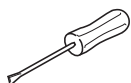
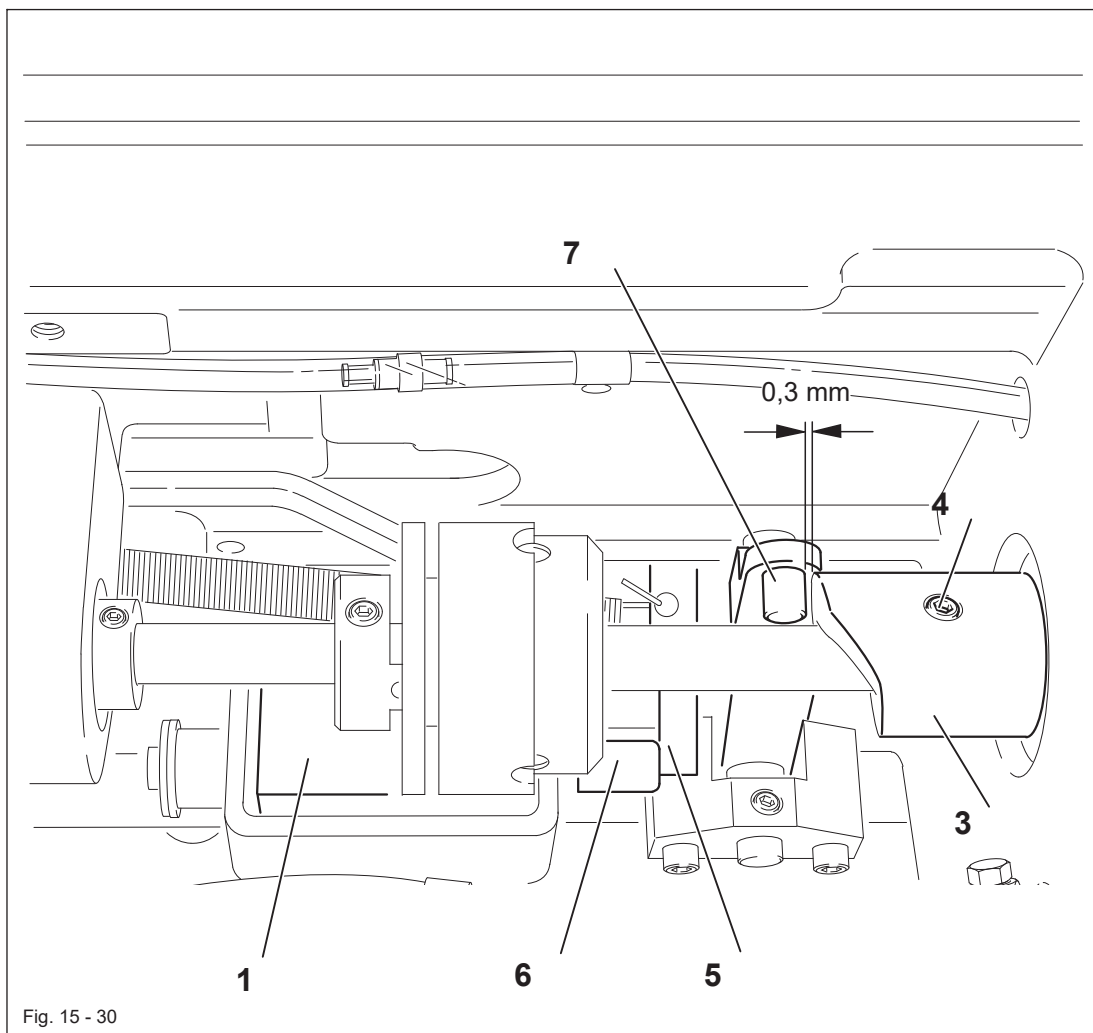

- ➡ Having made sure that piston **6** is positioned against the left stop, adjust magnet **1** (2 screws) in accordance with requirement **1**.
- ➡ Adjust control cam **3** (screws **4**) in accordance with requirement **2**.

15.06.02 Position of the thread catcher holder

Requirement

1. There should be a minimum amount of play between toothed wheel **3** and toothed segment **4**.
2. Both in the neutral position and the foremost position of the catcher, the distance between the toothed segment **4** and the outer edge of the thread catcher holder **1** should be the same (see arrow).

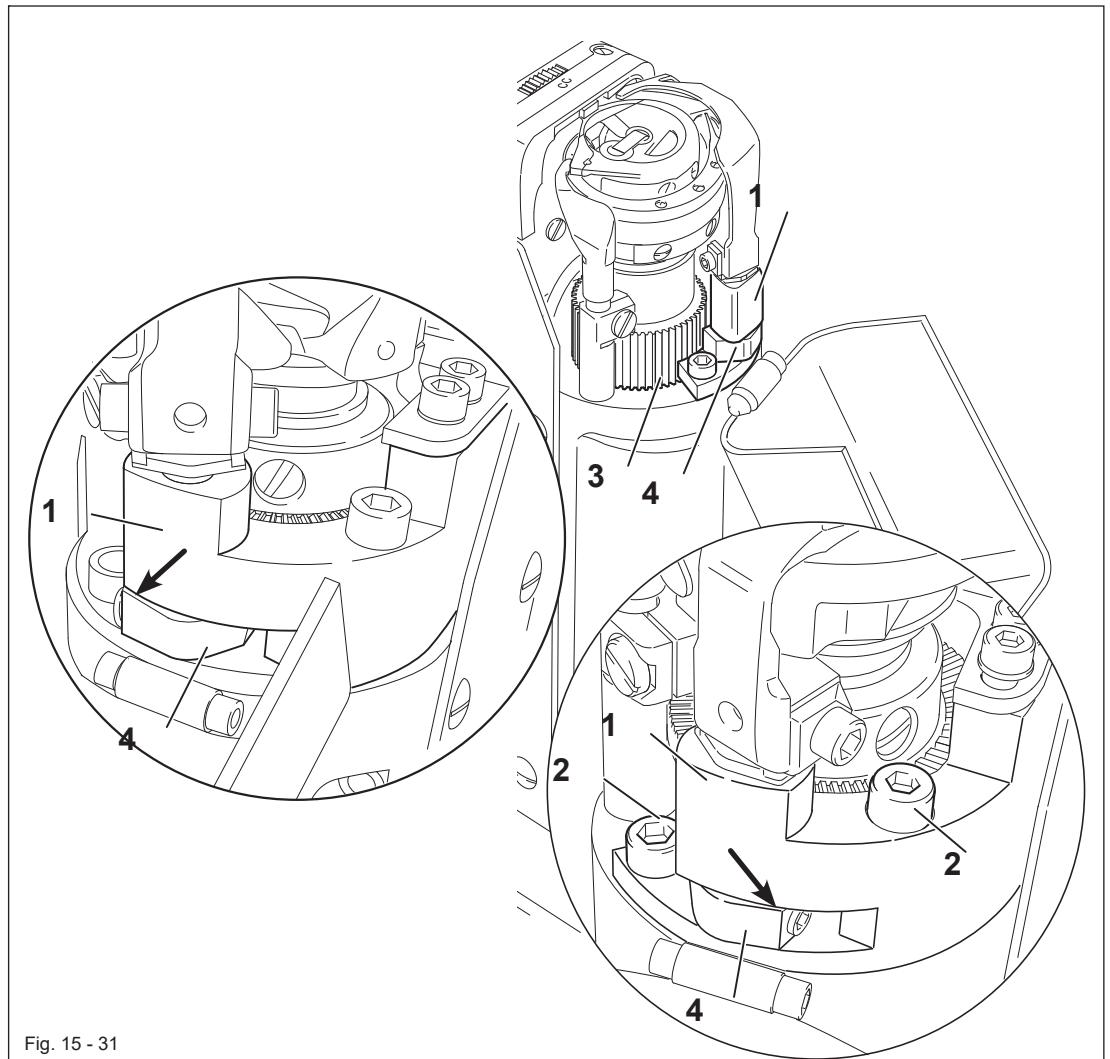
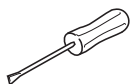

Fig. 15 - 31



➔ Adjust the thread catcher holder **1** (screws **2**) according to the requirements.



If **requirement 2** cannot be fulfilled, loosen screw **2** and move the toothed segment **4** by one tooth.

Adjustment

15.06.03 Distance between thread catcher and needle plate

Requirement

During its swivel movement thread catcher 1 should not pass the edge of the needle plate (see arrow)..

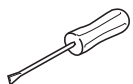
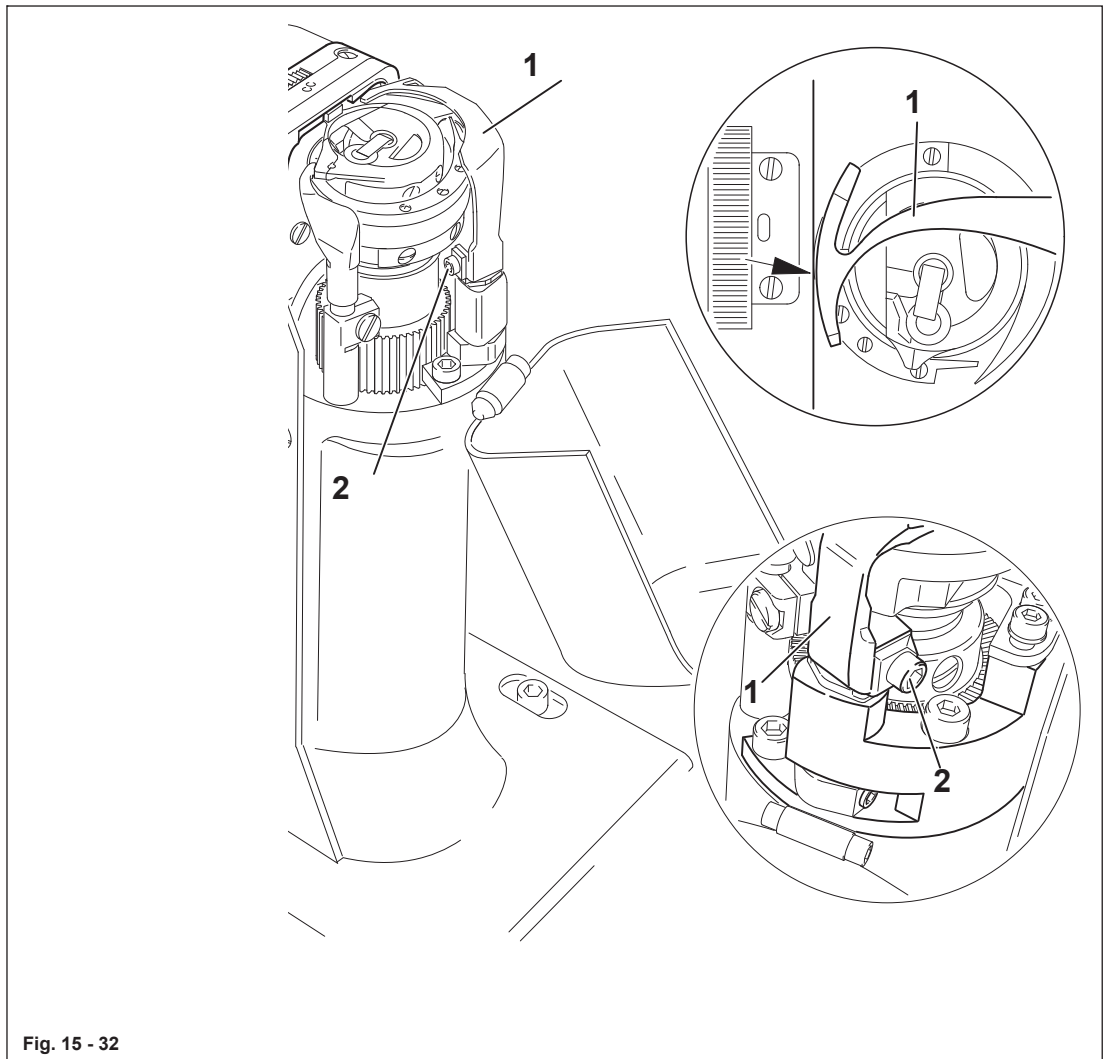

➡ Move thread catcher 1 (screws 2, two screws) parallel to the thread catcher holder in accordance with the requirement.

15.06.04 Position of the thread catcher

Requirement

1. The bottom edge of the thread catcher **1** should be at a distance of **0.1 mm** from the positioning finger of the bobbin case **5**.
2. When the thread trimmer is in its neutral position, the rear edge of thread catcher should be positioned approx. **2.5 - 3 mm** behind the edge of the knife **1**.

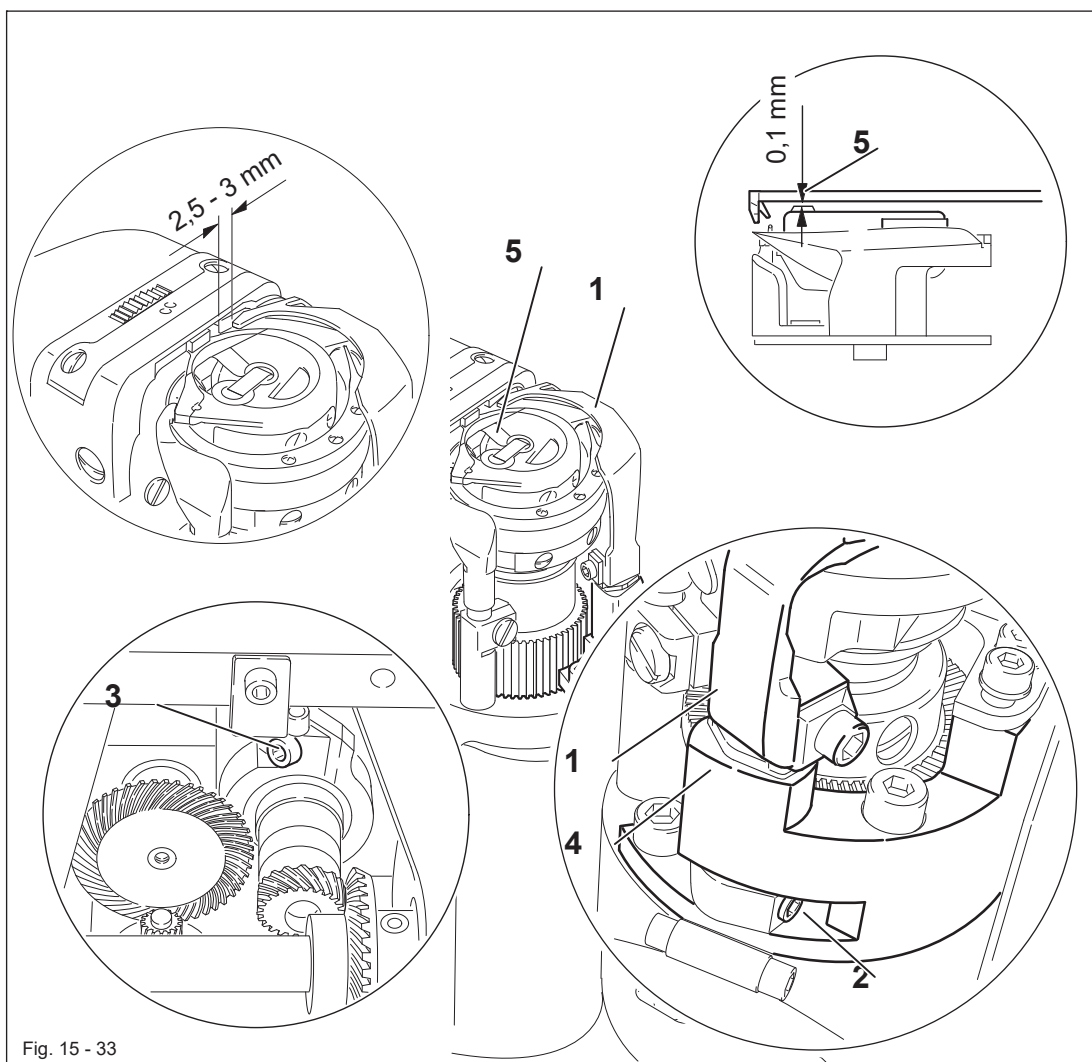
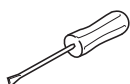

Fig. 15 - 33



- ➡ Move thread catcher **1** (screws **2**, two screws) in accordance with requirement **1**.
- ➡ Turn thread catcher **1** (screw **3**) in accordance with requirement **2**.



Thread catcher **1** must be parallel to the surface of the thread catcher holder **4**.

Adjustment

15.06.05 Knife position and knife pressure

Requirement

1. The knife 1 should be touching the needle plate.
2. The knife pressure should be set as low as possible but the cutting operation should still be carried out reliably.

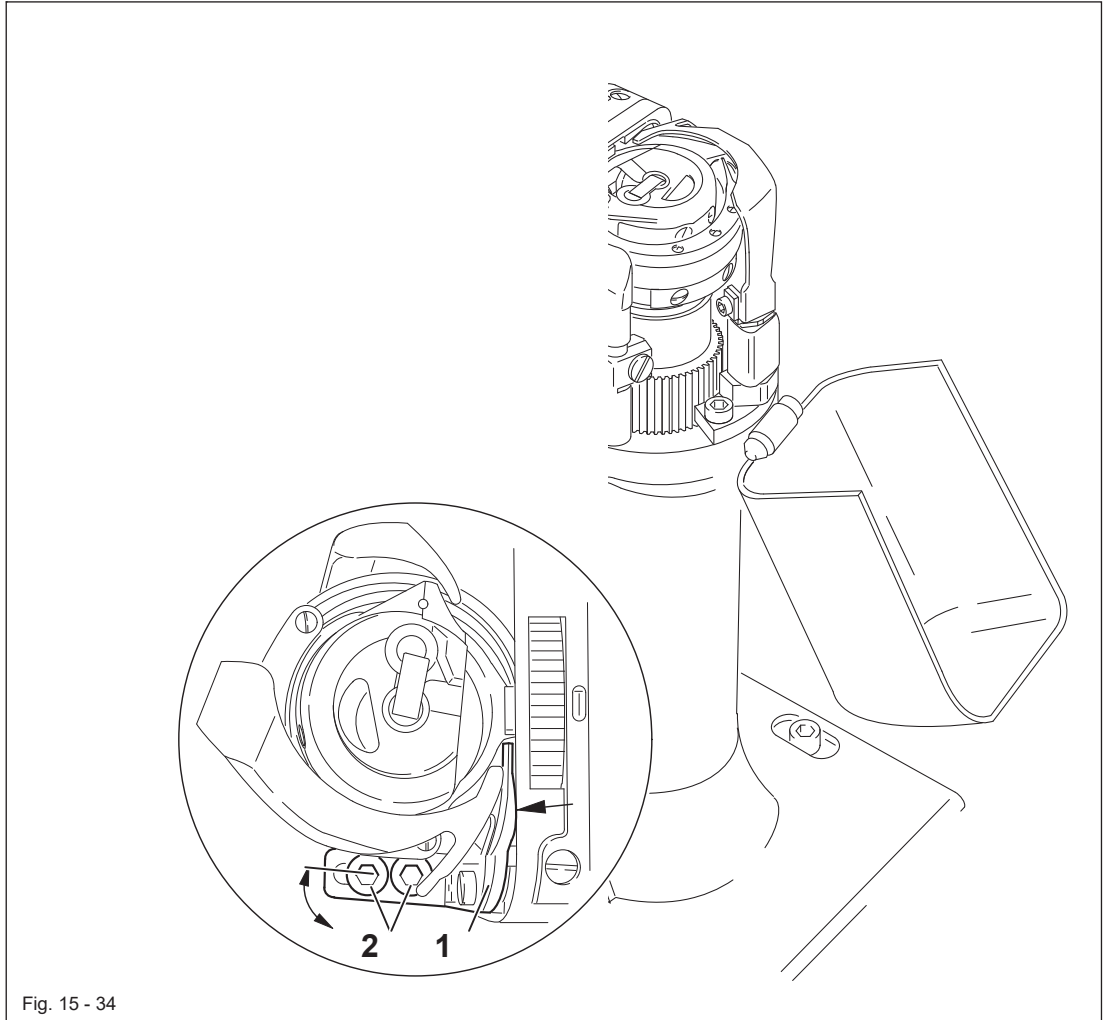
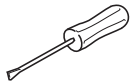

Fig. 15 - 34



- ➔ Move knife 1 (screws 2) in accordance with **requirement 1** or swivel it in accordance with **requirement 2**.

15.06.06 Bobbin thread retaining spring

Requirement

1. The bobbin thread clamp spring should be guided reliably in the thread groove of the thread catcher 3.
2. The tension of the bobbin thread spring clamp should be as low as possible, but the bobbin thread should be held reliably after the cutting operation.

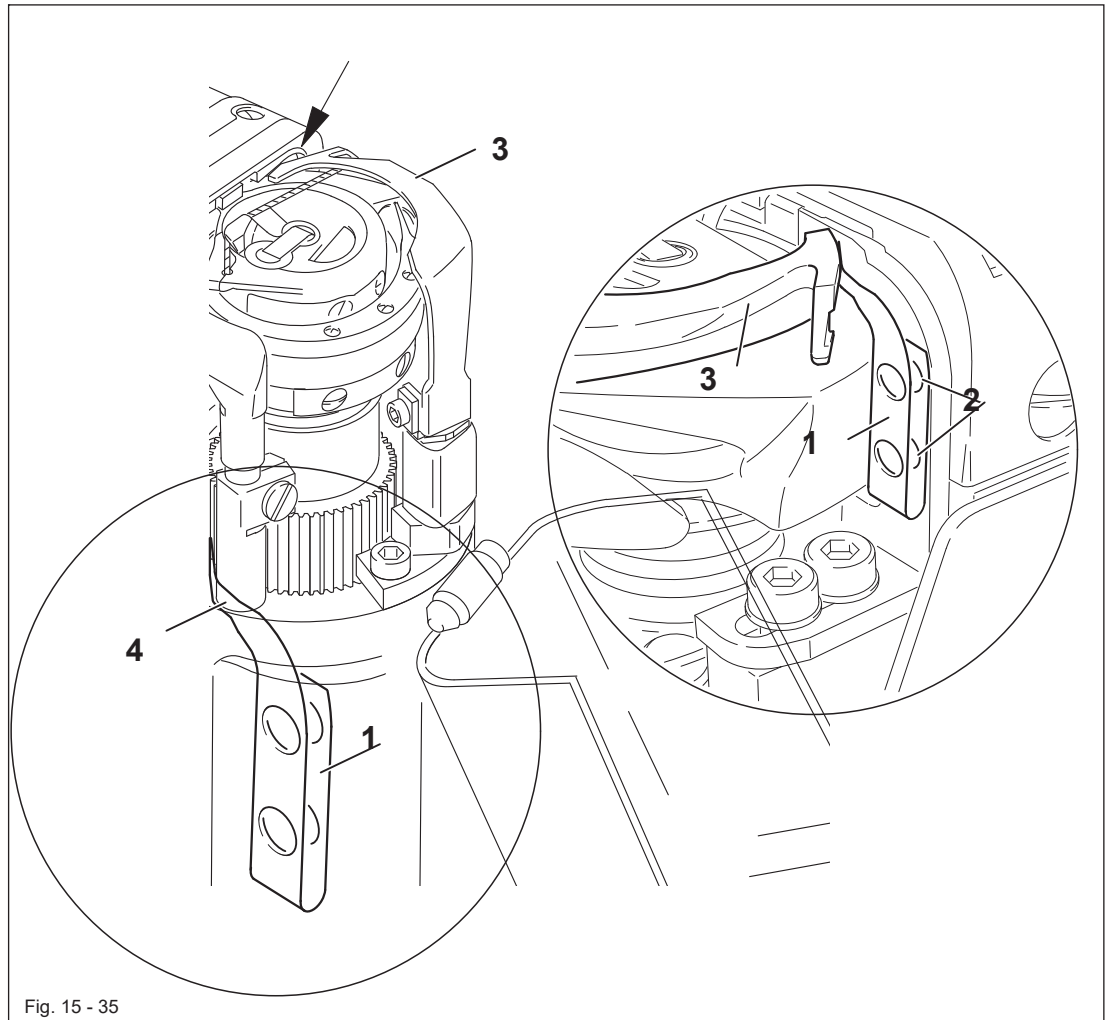
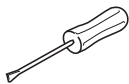

Fig. 15 - 35



- Adjust bobbin thread clamp spring 1 (screws 2) in accordance with requirement 1.
- Adjust the tension in accordance with requirement 2 by bending side 4 of the bobbin thread clamp spring 1.
- **Control - requirement 1**
- Switch off the machine and bring the take-up lever to its b.d.c.
- Engage and disengage the thread catcher 3 by hand and check **requirement 1**. Adjust if necessary.
- **Control - requirement 2**
- After the thread has been cut, sew a few stitches by turning the balance wheel, checking whether the bobbin thread is drawn out of the bobbin thread clamp spring between the 1st and 3rd stitches. If necessary, correct the tension.

Requirement

1. When thread catcher **1** is on its forward stroke, it must not carry bobbin thread **3** forward too.
2. When thread catcher **1** is in its front position, bobbin thread **3** must be held reliably by hook **4**.
3. After the trimming action, both the needle thread and the bobbin thread must be perfectly cut and bobbin thread **3** retained.

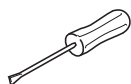
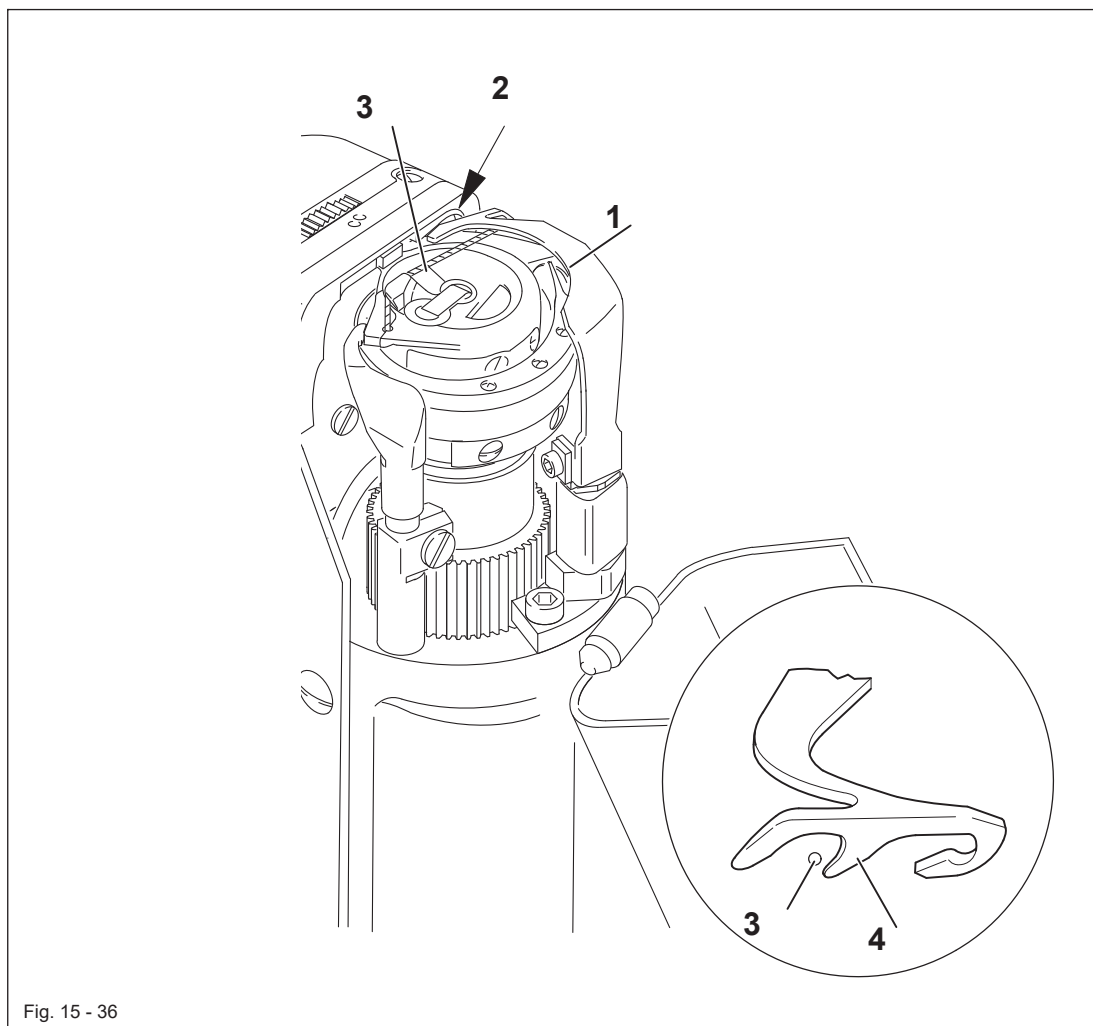

- ➡ Sew a few stitches.
- ➡ Turn off the on/off switch.
- ➡ Carry out the cutting operation manually.
- ➡ Check requirement **1** and **2**, and if necessary readjust thread catcher **1** in accordance with **Chapter 15.06.04 Position of the thread catcher**.
- ➡ Check requirement **3**, and if necessary readjust the bobbin thread retaining spring **2** in accordance with **Chapter 15.06.06 Bobbin thread retaining spring**.

15.06.08 Linkage rod (only on the PFAFF 1574)

Requirement

The driving levers 1 should be parallel when the thread trimmer is the neutral position.

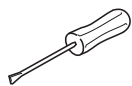
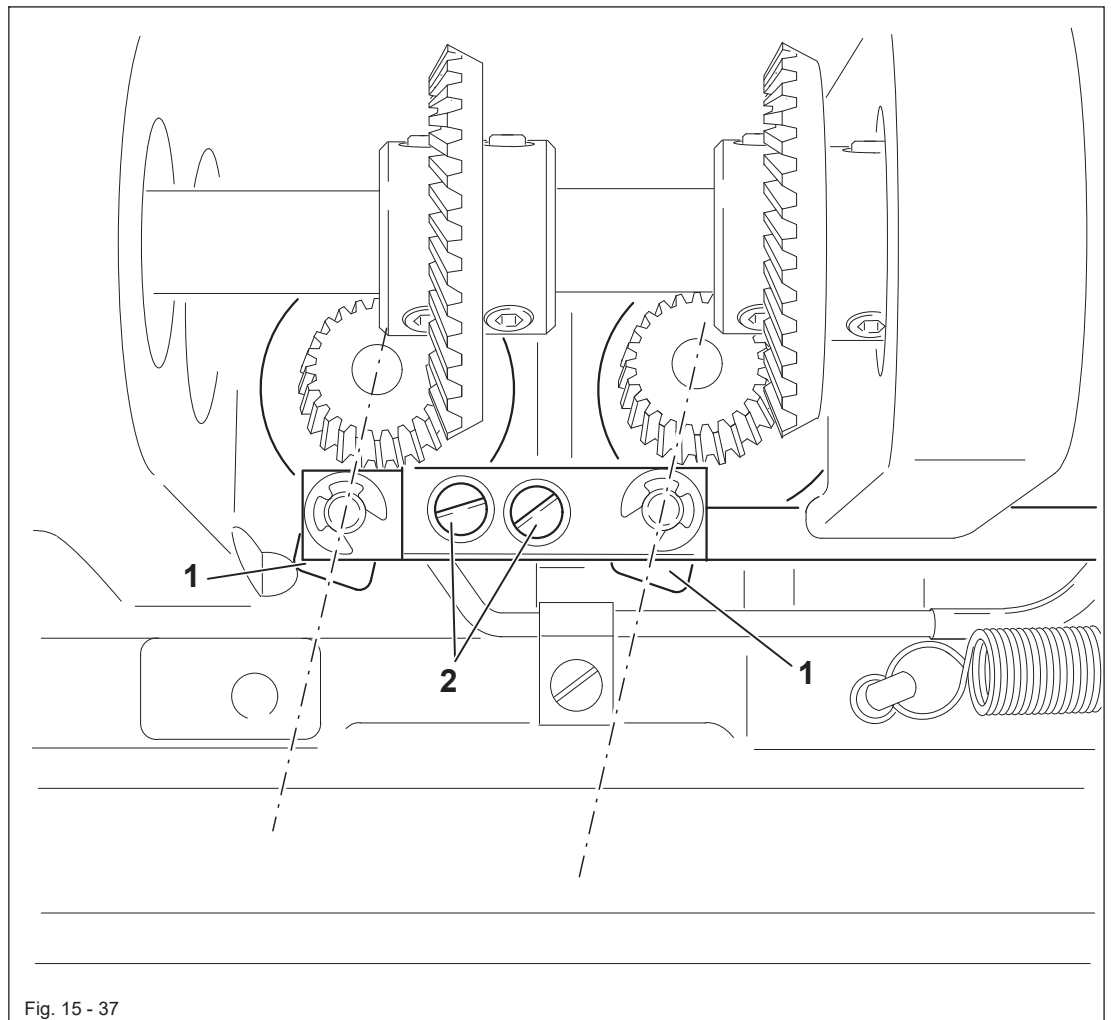

➡ Adjust the driving levers 1 (screws 2) according to the requirement.

15.07 Parameter settings

15.07.01 Overview of parameter functions (with BDF S5)

After switching on the machine, call up the input mode in which the individual parameters can be called up by pressing the corresponding function. All parameter groups or also individual ones can be protected by a code against unauthorised access.

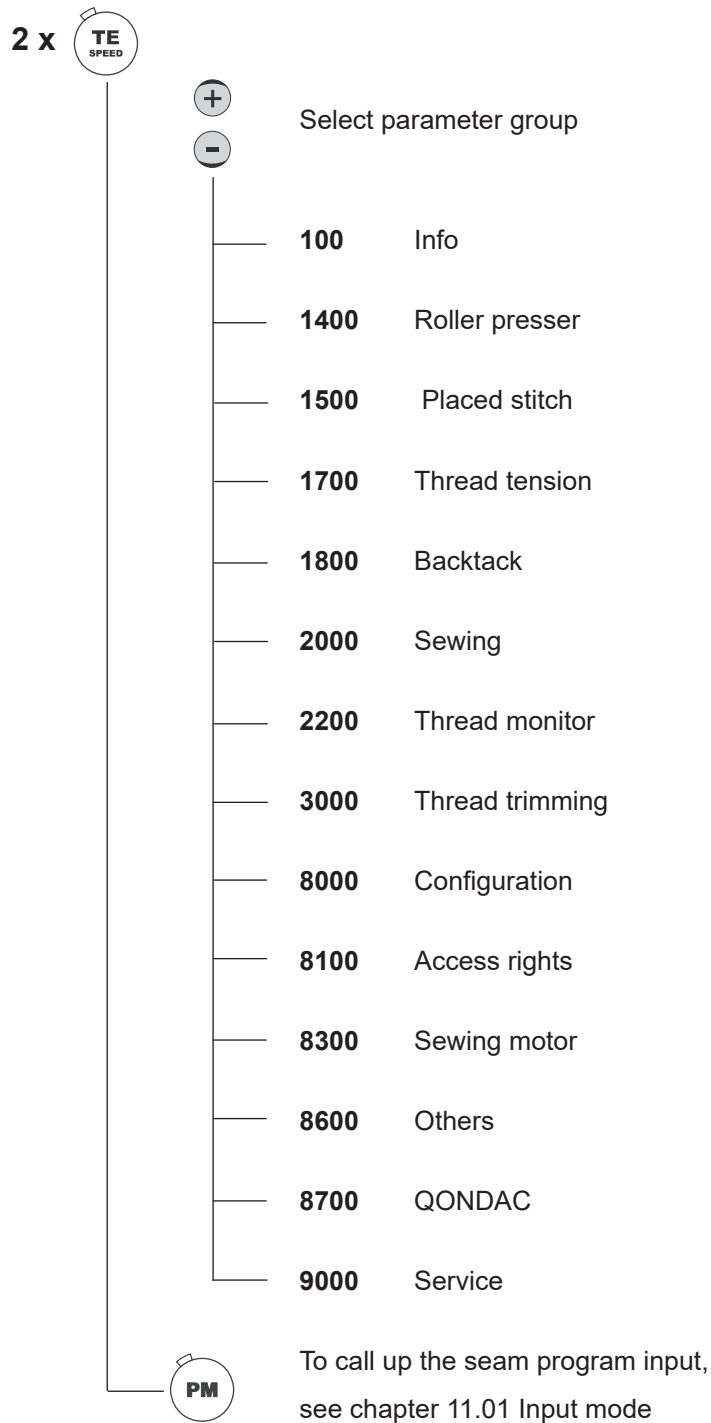

For a more detailed description of parameter functions, see chapter

15.07.05 List of parameters.

15.07.02 Overview of parameter functions (with BDF P1)

After switching on the machine, call up the input mode in which the individual parameters can be called up by pressing the corresponding function. All parameter groups or also individual ones can be protected by a code against unauthorised access.

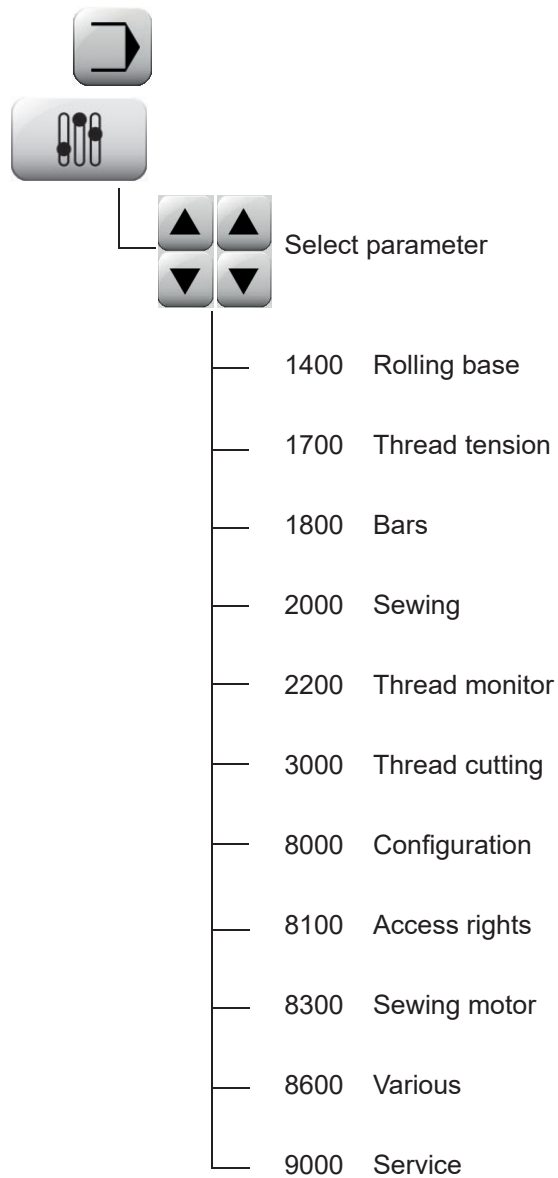

Adjustment

15.07.03 Example of a parameter entry (with BDF S5)

⇒ Switch the machine on.



⇒ Press the TE/Speed key twice to access the parameter entry function.

The status text "TE" appears on the display and the pedal functions are locked to prevent an accidental start-up of the machine.

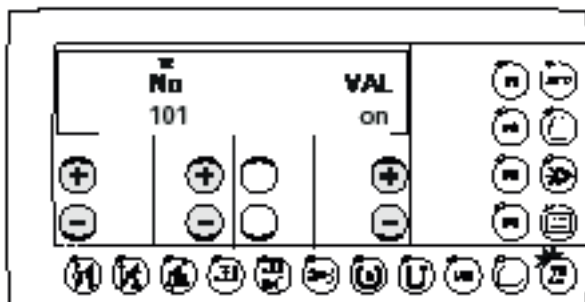

No ⇒ Select the desired parameter, e.g. "660" bobbin thread monitor by pressing the corresponding +/- keys.

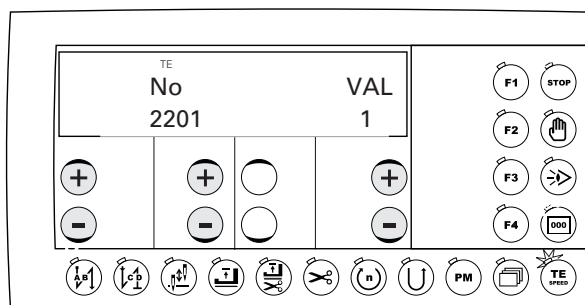

VAL ⇒ Set the desired value for the parameter, e.g. "0" to switch off the bobbin thread monitor by pressing the corresponding +/- key.
Possibly. Enter code 1500.

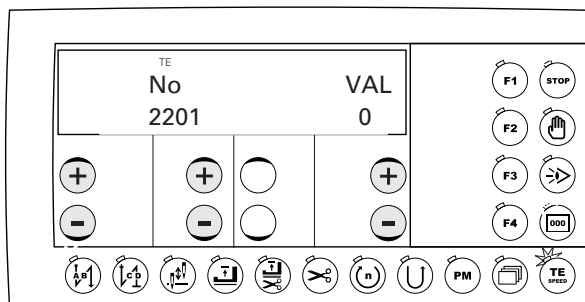

⇒ The value is taken over and the machine switches to sewing mode by pressing the TE/Speed key.

15.07.04 Example of a parameter entry (with BDF P1)

➔ Switch the machine on.

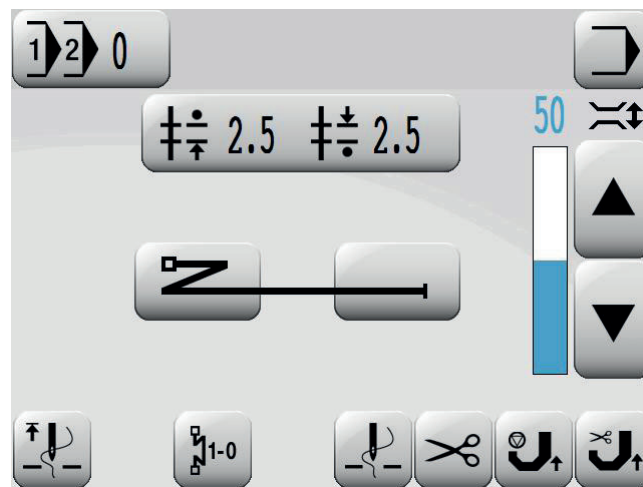

➔ Call up input mode



➔ Call parameter input.

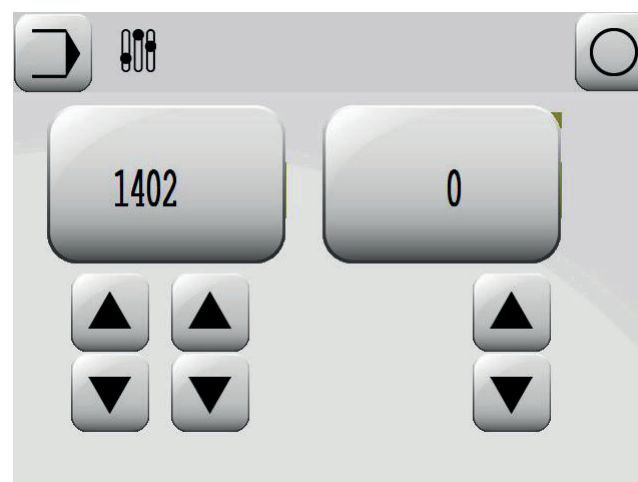

➔ For example, call up parameter "2201"

Adjustment

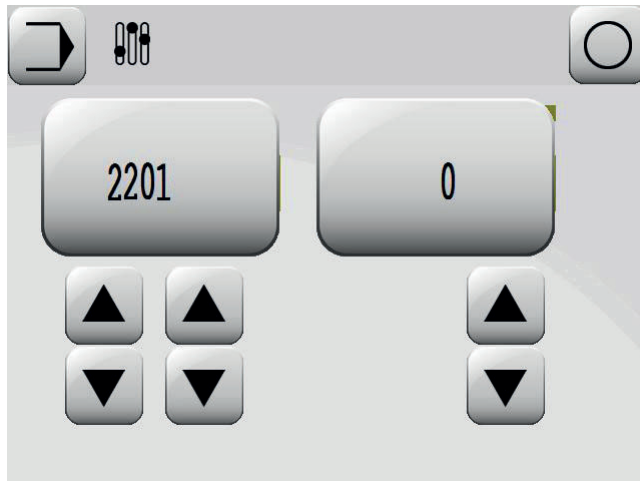

⇒ If necessary, Enter the code number, see **chapter 9.10 Entering / changing the code number**.



⇒ For example, set value 1.

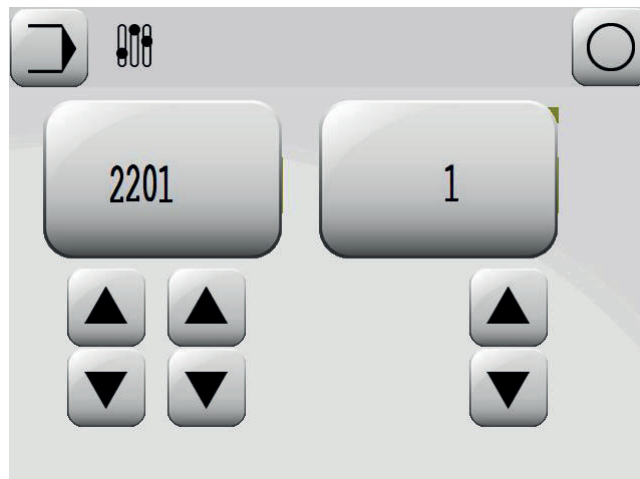

⇒ **Conclude the input.**

15.07.05 Parameter list for control P430SD

Group	Parameter	Description	Setting range	Set value 1574	Set value 1571; 1591; 1593
100	101	Display main processor software version	0461/xxx		
	102	Show software version of the bootloader	0458/xxx		
	103	Display sewing drive component software version	0427/xxx		
	104	Display control panel software version	VxxxHyyy		
	196	Display hardware ID of the controller			
	197	Show serial number of the controller	600-xxxx-xxxxxx		
	198	Show serial number			
	199	Display product number			
1400	1402	Roller presser lowering speed 0 = slow, 1 = quick	0 - 1	0	0
	1460	Holdoff time roller presser lift	0,001s - 1,500s	0,050s	0,050s
	1461	Lower start delay after roller presser	0,001s - 1,500s	0,050s	0,050s
	1462	Set roller presser lift Must be increased for high foot pressure	0,001s - 0,200s	0,080s	0,080s
	1480	Roller presser magnet pulse	10%-50%	35%	35%
1500	1501	Placed stitch , 0 = OFF, 1 = ON	0 - 1	0	0
	1520	Placed stitch position	0° - 359°	20°	20°
1700	1703	Open thread tension on stop and roller presser lift 0 = OFF, 1 = ON	0 - 1	1	1
	1704	Open thread tension after trimming and roller presser lift 0 = OFF, 1 = ON	0 - 1	1	1
	1720	Thread tension ventilation position	0° - 359°	290°	300°(1571) 300°(1591) 290°(1593)
	1760	Time thread tension ventilation before timing	0,001s - 1,500s	0,100s	0,100s
	1780	Thread tension magnet timing	10%-50%	35%	35%
1800	1840	Start backtack speed	100 - 1500	700	700
	1841	End backtack speed	100 - 1500	700	700
2000	2010	Stitch length at the touch of a button (parameter stitch)	0,8 - 7,0mm	4,0mm	4,0mm
	2011	Soft starting stitches	0 - 15	0	0
	2040	Soft start speed	100 - 3500	1500	1500
	2041	Minimum speed	100 - 300	180	180
	2042	Maximum speed	100 - 3500	3500	3500

Adjustment

Group	Parameter	Description	Setting range	Set value 1574	Set value 1571; 1591; 1593
3000	3003	Reverse rotation , 0 = OFF, 1 = ON	0 - 1	1	1
	3020	Thread trimmer magnet position on	0° - 359°	66°	48°(1571) 48°(1591) 66°(1593)
	3021	Thread trimmer magnet position timing	0° - 359°	235°	283°(1571) 283°(1591) 235°(1593)
	3022	Thread trimmer magnet position off	0° - 359°	348°	339°(1571) 339°(1591) 348°(1593)
	3026	Reverse rotation position	0° - 359°	340°	283°(1571) 283°(1591) 340°(1593)
	3040	Cutting speed	100 - 300	180	180
	3060	Waiting time before turning back	0,001s - 1,500s	0,020s	0,020s
	3080	Thread trimmer magnet timing	10% - 50%	35%	35%
8000	8002	Take-up lever at t.d.c. position	0° - 359°	6°	353°(1571) 353°(1591) 6°(1593)
	8003	Position of needle at t.d.c. bottom position	0° - 359°	66°	48°(1571) 48°(1591) 66°(1593)
	8004	Machine configuration	1 - 9	2	1(1571) 1(1591) 9(1593)
	8005	Single stitch key assignment 1 = half stitch 2 = single stitch 3 = double stitch 4 = parameter stitch (parameter 2010) 5 = needle up 6 = Target stitch in sewing at 1574 7 = Not high 8 = knee switch	1 - 8	2	2
	8006	Half stitch key assignment 1 = half stitch 2 = single stitch 3 = double stitch 4 = parameter stitch (parameter 2010) 5 = needle up 6 = Target stitch in sewing at 1574 7 = Not high 8 = knee switch	1 - 8	1	1
	8025	Adjust sewing motor on sewing head (Needle top edge stitch plate)		31° ± 6°	23° ± 6°(1571) 23° ± 6°(1591) 31° ± 6°(1593)

Group	Parameter	Description	Setting range	Set value 1574	Set value 1571; 1591; 1593
8100	8101	Access rights for function group 100* (Info)	0 - 1	0	0
	8104	Programming access rights*	0 - 1	1	1
	8114	Access rights for function group 1400*(Roller presser)	0 - 1	1	1
	8115	Access rights for function group 1500* (Placed stitch)	0 - 1	1	1
	8117	Access rights for function group 1700* (Thread tension)	0 - 1	1	1
	8118	Access rights for function group 1800* (Backtack)	0 - 1	1	1
	8120	Access rights for function group 2000* (Sewing)	0 - 1	0	0
	8122	Access rights for function group 2200* (Thread monitor)	0 - 1	1	1
	8130	Access rights for function group 3000* (Thread trimming)	0 - 1	1	1
	8180	Access rights for function group 8000* (Configuration)	0 - 1	1	1
	8181	Access rights for function group 8100* (Access rights)	0 - 1	1	1
	8183	Access rights for function group 8300* (Sewing motor)	0 - 1	1	1
	8186	Access rights for function group 8600* (Others)	0 - 1	0	0
	8187	Access rights for function group 8700* (QONDAC)	0 - 1	1	1
	8190	Access rights for function group 9000* (Service)	0 - 1	1	1
	8199	Input access code	0 - 9999	1500	1500
8300	8301	P-section speed regulator	3 - 200	80	80
	8302	I-section speed regulator	0 - 200	80	80
	8303	P-section position controller	1 - 50	20	20
	8304	D-section position controller	1 - 100	30	30
	8305	Time for position controller	0,000s - 2,000s	0,250s	0,250s
	8306	P-section position controller for remainder brake	0 - 50	25	25
	8307	Maximum torque for remainder brake	0 - 50	0	0
	8308	Acceleration ramp	1 - 50	35	35
	8310	Braking ramp	1 - 50	35	35
	8311	Positioning speed	60 - 300	180	180
	8312	Dead man time	0,000s - 0,250s	0,150s	0,150s
	8314	Positioning technique	1 - 2	1	1
	8316	Motor starting current	7 - 15	12	12
	8317	Pilot during acceleration	0 - 100	0	0
8318	Input taxes when decelerating	0 - 100	10	10	
8600	8601	Control panel key tone 0 = OFF, 1 = ON	0 - 1	1	1
	8602	Key tone when switching over between zones 0 = OFF, 1 = ON	0 - 1	0	0
8700	8701	Networking 0 = OFF, 1 = ON	0 - 1	0	0
	8780	Enter Customer ID (15 characters alphanumeric)			

Adjustment

Group	Parameter	Description	Setting range	Set value 1574	Set value 1571; 1591; 1593
9000	9001	Move roller presser and feed wheel and needle stepping motor			
	9002	Inputs: 0123456789ABCDEF			
		MACHINE:			
		0= reversing key on the machine head (E1)			
		1= single stitch key on the machine head (E2)			
		2= half stitch key on the machine head (E3)			
		3= free (E4)			
		4= knee switch (E5)			
		5= start inhibitor (E6)			
		6= photo cell (E7)			
		7= Material thickness with PFAFF 3834 (E8)			
		8= free (E9)			
		9= free (E10)			
		A= free (E11)			
		B= free (E12)			
		C= free (E13)			
		D= free (E14)			
		E= free (E15)			
		F= free (E16)			
		After key scroll:			
		SPECIAL:			
		0= Reference SM1			
		1= Reference SM2			
		2= Reference SM3			
		3= Busy SM1			
		4= Busy SM2			
		5= Busy SM3			
		6= Error SM1			
		7= Error SM2			
		8= Error SM3			
		9= Track A Incremental encoder #1			
		A= Track B Incremental encoder #1			
		B= 180° Track			
	C= 180° Track at translation				
	D= Track A Incremental encoder #2				
	E= Track B Incremental encoder #2				

Group	Parameter	Description	Setting range	Set value 1574	Set value 1571; 1591;1593
9000	9003	Outputs test			
		A1= Roller presser lift			
		A2= free			
		A3= free			
		A4= Thread trimming			
		A5= free			
		A6= Tension ventilation			
		A7= free			
		A8= free			
		A9= free			
		A10= free			
		A11= free			
		A12= Sewing engine is running			
		A13= free			
		A14= free			
		A15= free			
		A16= LED on the machine head			
		A17= free			
		A18= free			
		A19= free			
	9004	Display values of the two setpoint transmitters			
	9005	Turn sewing motor			
	9006	Thread tension magnets			
	9099	Run cold start			

Error	Description
E 001	System error
E 002	Sewing motor E002/BB/xxx BB = 20: Deadman 01: Switch on speed 02: Positioning 03: Start distance 04: Read distance 05: Set translation 06: Read translation 07: Error reset 08 Write parameters 09: Read version 0A: Read speed 0B: Read actual position 0C: Delete distance xxx = Sewing motor controller error byte (see motor error)
E 003	Seam zone data
E 004	Flash memory
E 005	No room on the heap
E 006	Mains voltage outside the work area
E 007	24V IO power supply E007/xx xx= 1: Short circuit 2: overload 3: 5V timeout when switching on 4: 20 V timeout when switching on
E 008	60V SM power supply E008/xx xx= 1: Short circuit 2: overload 3: 20V timeout when switching on 4: 50 V timeout when switching on 5: 60 V not reached after switching on
E 009	Encoder of the sewing drive not plugged in
E 017	Serial interface E017/xx xx= 4: dead man expired 5: Number of communication attempts exceeded 6: Lost USB connection
E 019	Sewing motor has no 180 ° track
E 020	CAN interface E020/xx xx= 1: Number of CAN nodes wrong 2: Hardware error (possibly short circuit) 3: Communication
E 021	Button pressed when switching on
E 022	Pedal activated when machine turned on

Error	Description
E 040	Stepper motor 1 E040/xx xx= 1: Wrong command 2: Overtemperature 3: Excess current
E 041	Stepper motor 2 E041/xx xx= 1: Wrong command 2: Overtemperature 3: Excess current
E 042	Stepper motor 3 E042/xx xx= 1: Wrong command 2: Overtemperature 3: Excess current
E 101	Program number invalid (3 - 99)
E 102	Error in the sewing program
E 106	Incorrect stitch length
E 107	Ramp not completed
E 110	Needle drive mid-point not found
E 111	Sewing displacement error
E 125	Fatal, unrecoverable internal error
E 300	Error in program E300 / xx xx= 9: Program not available 13: Error in the program
E 301	Error with Commander E301 / xx xx= 1: Directory full 2: Directory could not be created 3: directory name 4: List of machine data must not be deleted 5: Machine data can not be deleted 6: Directory can not be deleted (not empty?) 7: File can not be deleted Files can not be deleted 9: Current directory can not be deleted 10: Marked files can not be deleted 11: not empty directory can not be deleted 12: Directory can not be copied 13: File can not be copied 14: File can not be overwritten 15: Directory can not be overridden 16: File can not be copied to itself: 17: Marked files can not be copied 18: Empty file 19: The directory of the machine data must not be copied 20: read-only

Error	Description
E 317	Interface to the controller E317 / xx xx = 1: buffer overflow 2: Receive ring buffer overflow 3: Sender input buffer overflow 11: Send 12: receiving 42: Checksum wrong 45: Timeout 45: Interface protocol 46: Timeout when sending the machine data

15.09 Sewing motor errors

Error	Description
48	Timeout for increasing speed
49	Timeout from deadman
50	Timeout for initialisation
51	Number of communication attempts exceeded
52	Timeout during communication
53	Invalid command
54	Checksum wrong
55	Invalid data
56	Parameter does not exist
57	Parameter limits exceeded or exceeded
58	Sewing motor has not turned yet
70	Motor blocked
71	External synchronization mark not found
72	Excess current (20A)
73	Sewing motor not plugged
74	Synchronization mark at the first attempt not found
75	Current sensors out of tolerance
76	Deadman expired
77	Error at brake resistor
78	Overvoltage
79	Undervoltage
80	Fatal, unrecoverable internal error
81	Synchronization mark of the sewing motor is missing
82	No valid hardware identifier
83	Ground fault of the sewing motor detected

15.10 Warning messages

Error	Description
Warning 2	Bobbin thread error

15.11 Updating (with SD card or USB)

- After downloading the PFP tool and the control software, open the PFP program.
- Select the machine type and under control unit SD-CARD or USB.
- The software version is displayed under report.
- Under programming copy the software to the drive with the SD-card or USB.
- With the machine switched off insert the SD-card or USB into the control panel.

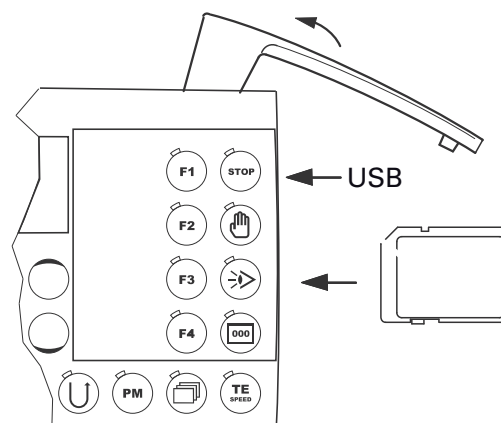
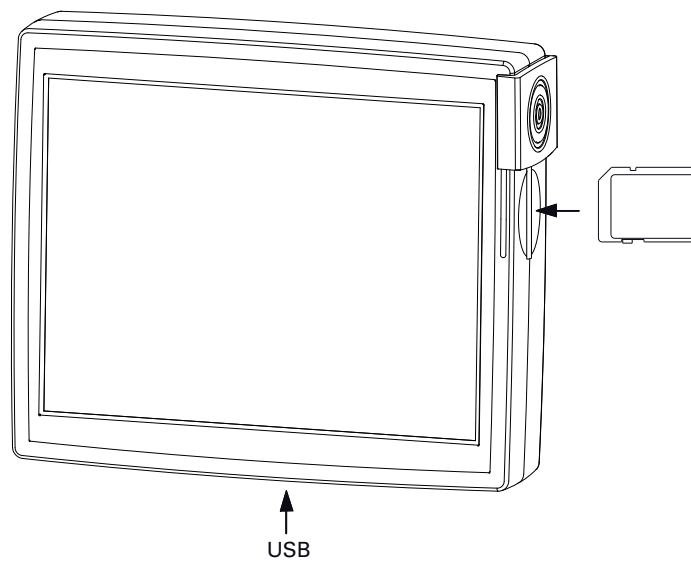

16 Circuit Diagrams 91-191 591-95

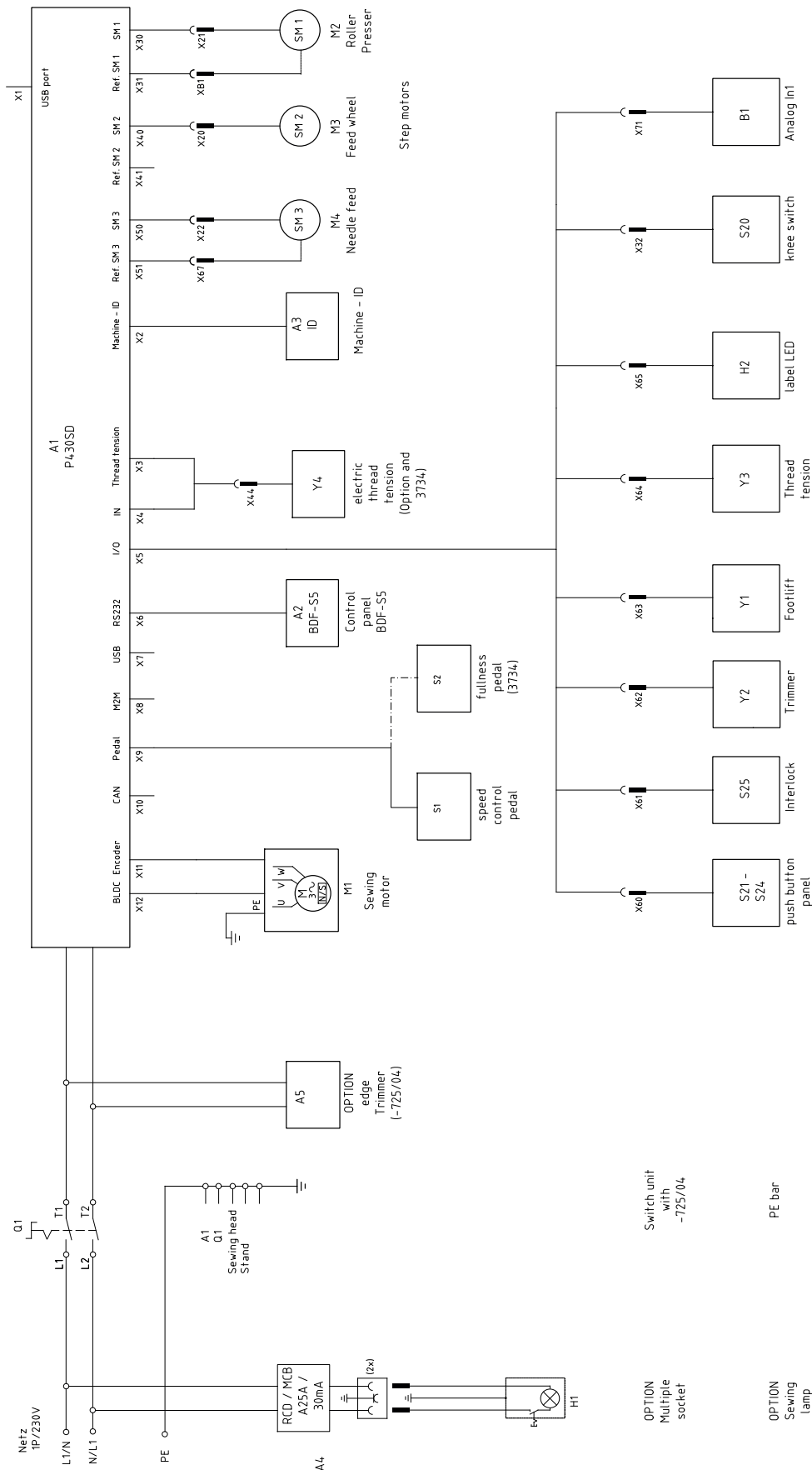

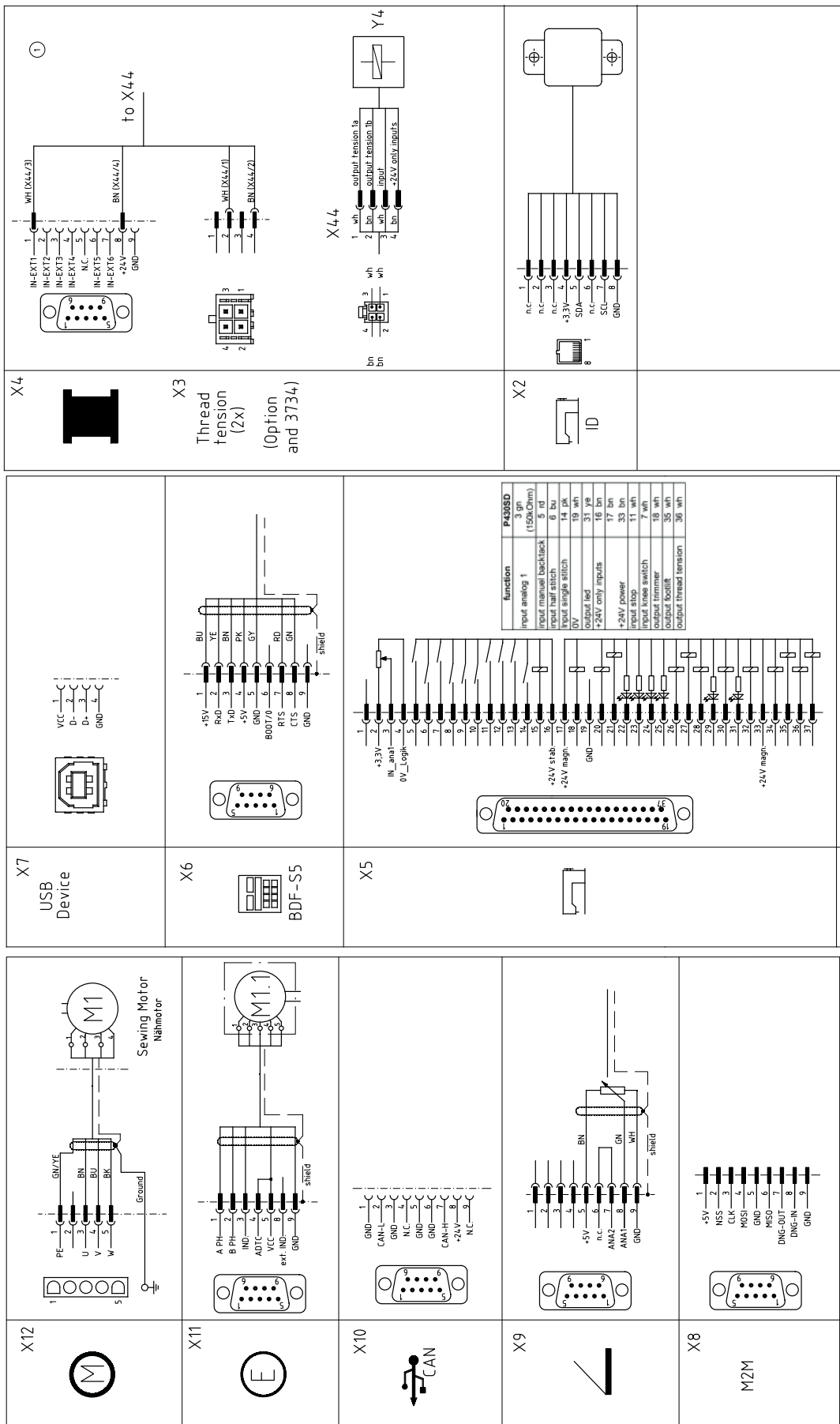

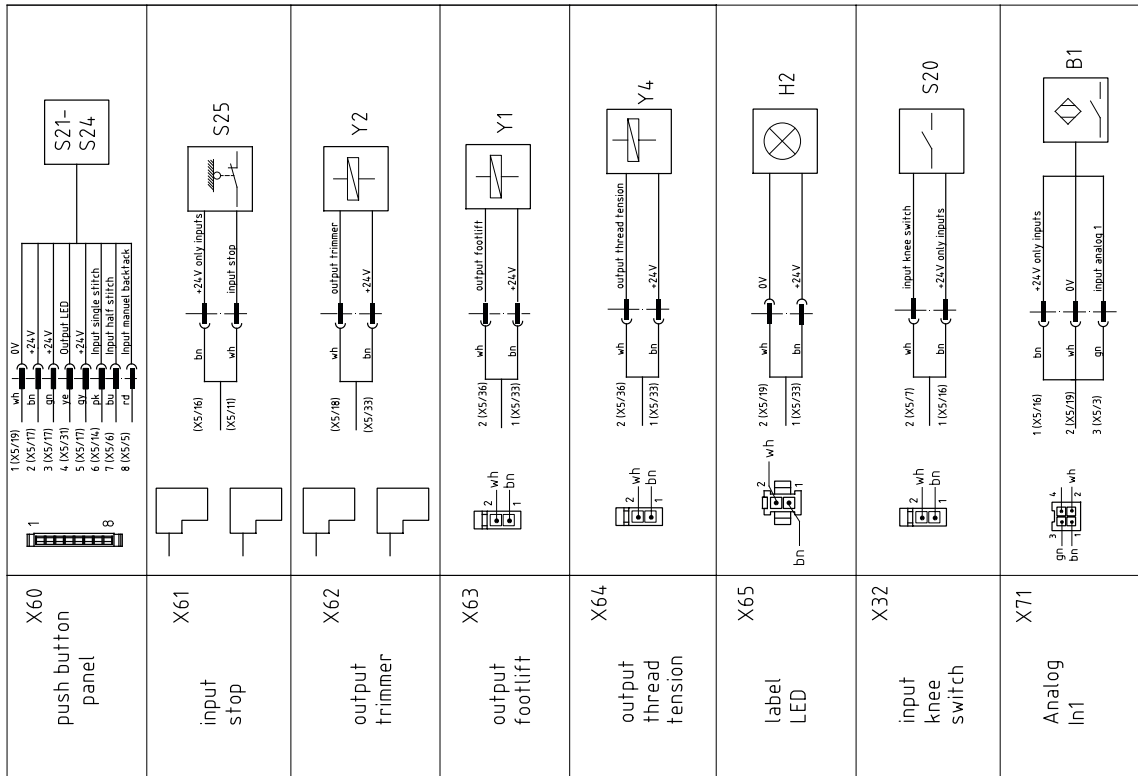
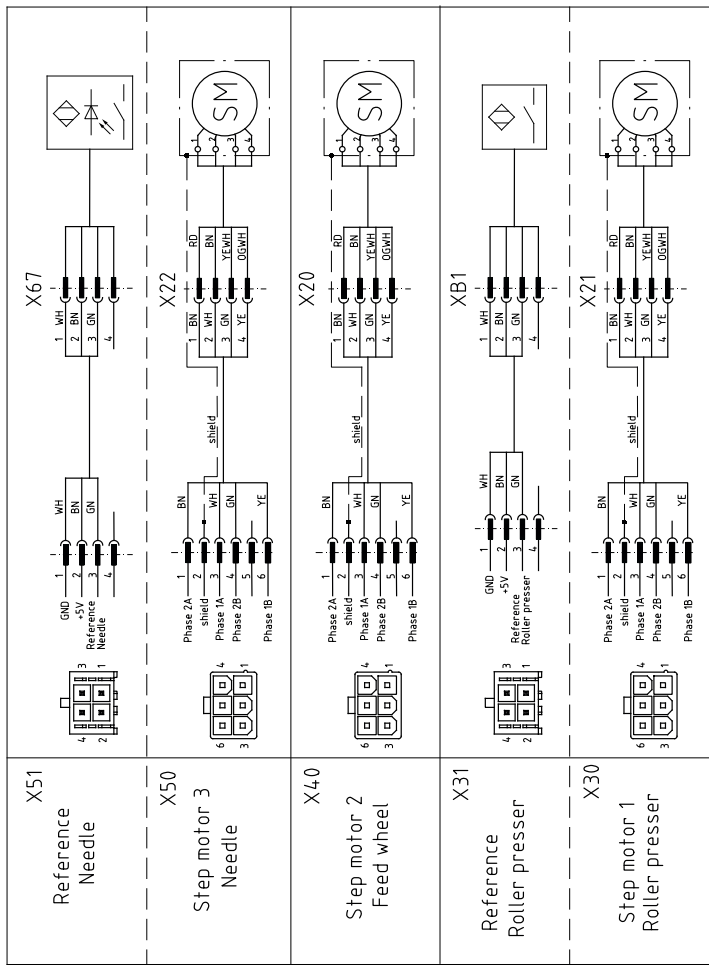

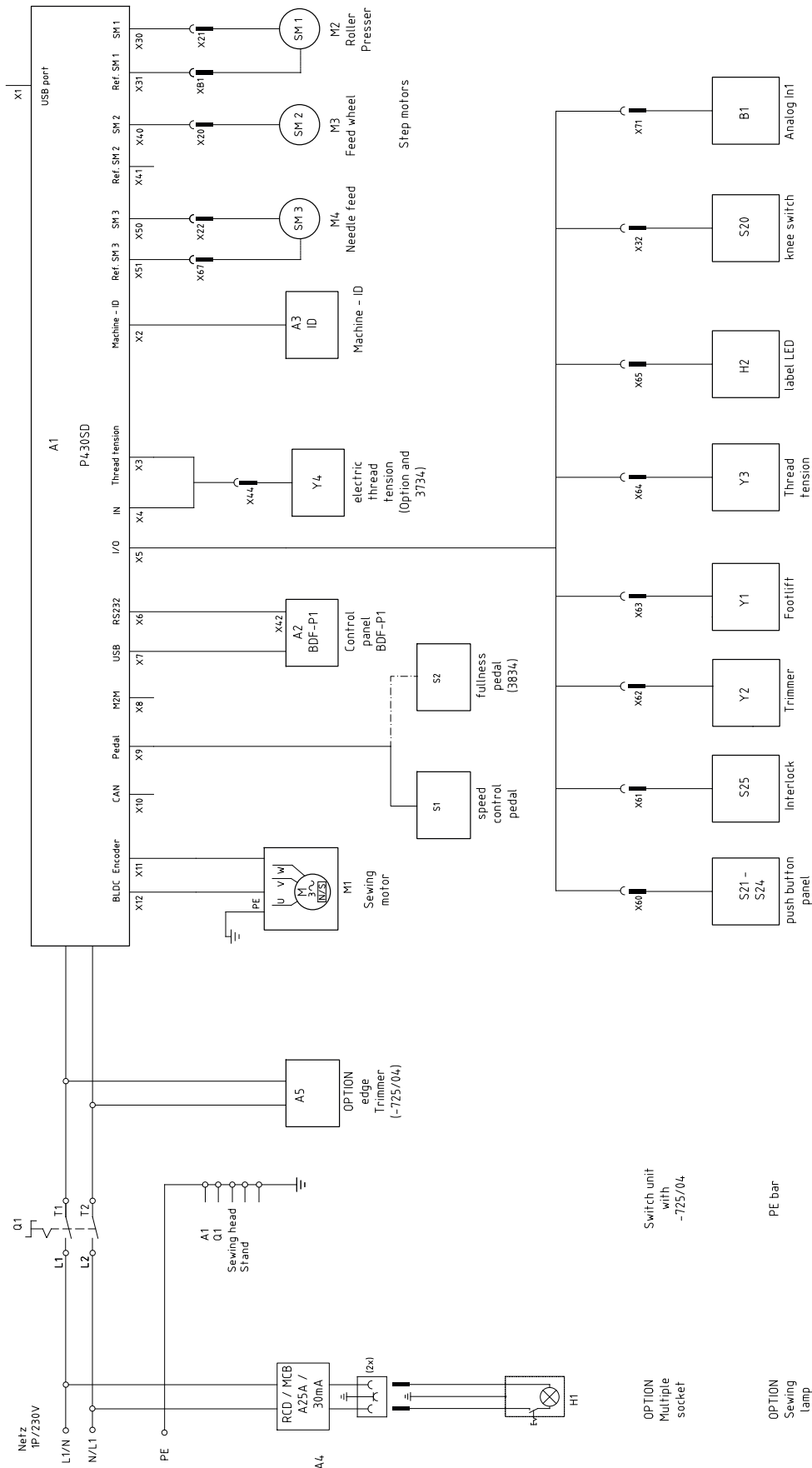

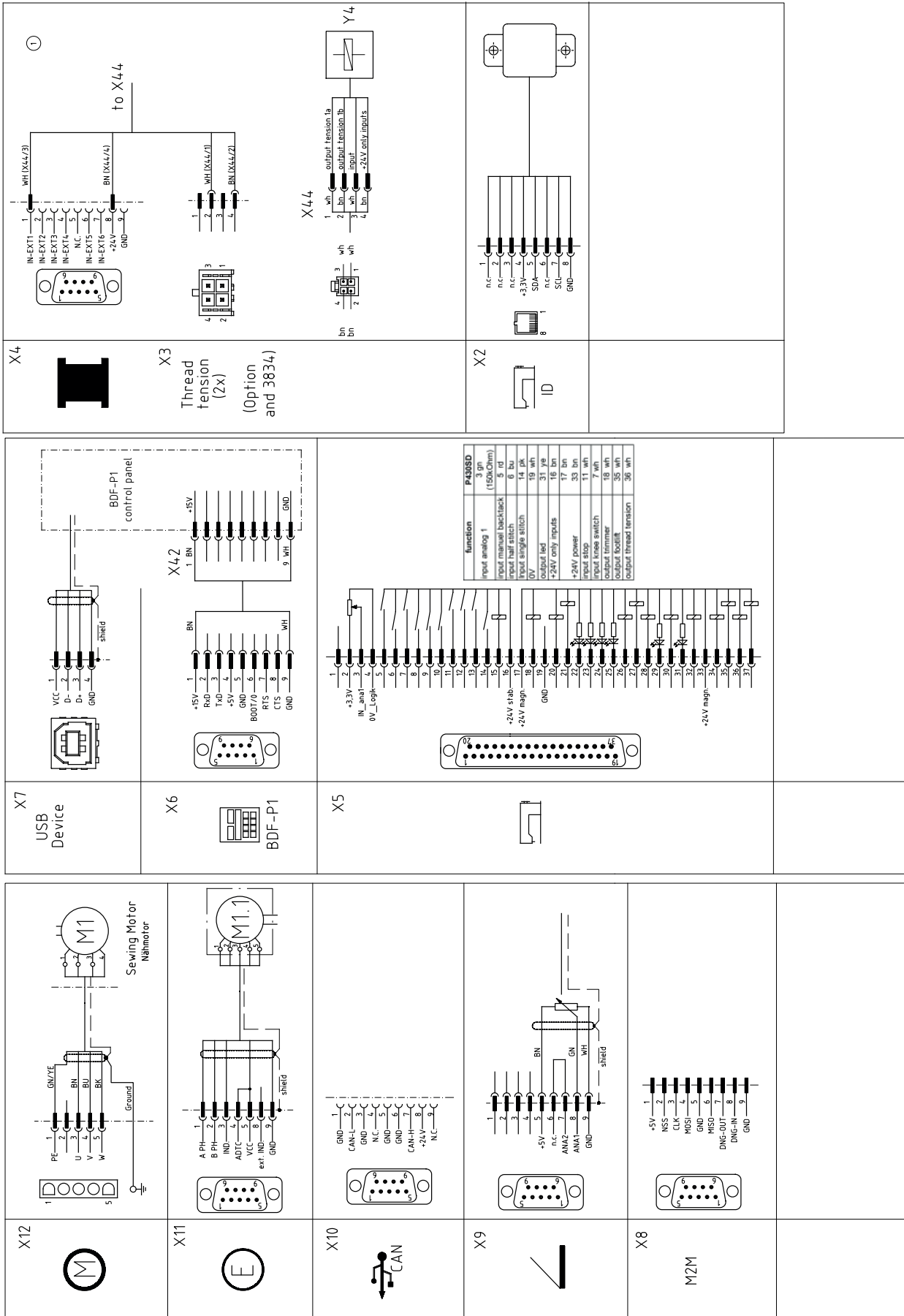

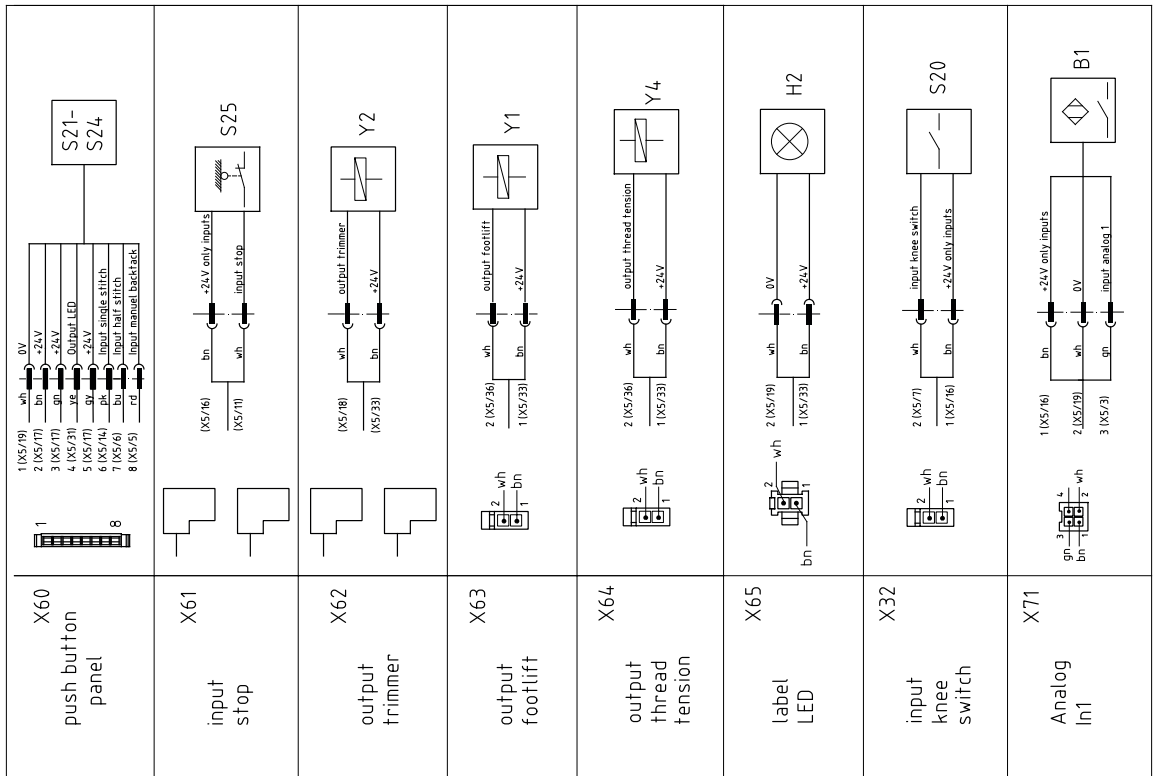
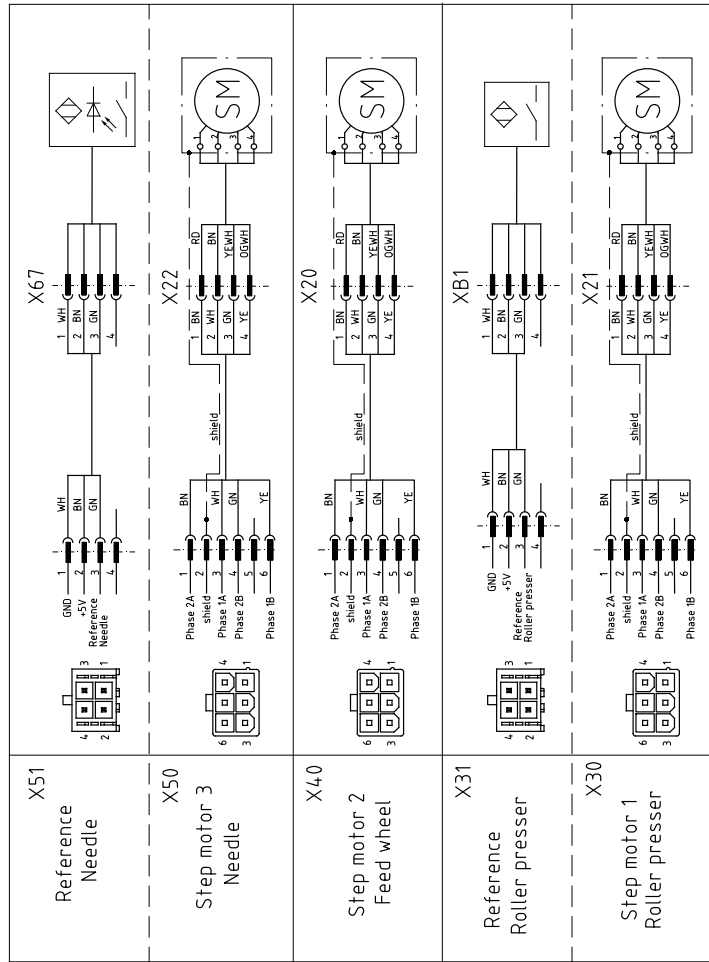

PFAFF® Industrial

CSKSL



Europäische Union
Wachstum durch Innovation – EFRE

PFAFF Industriesysteme und Maschinen GmbH

Hans-Geiger-Str. 12 - IG Nord
D-67661 Kaiserslautern

Tel.: +49-6301 3205 - 0

Fax: +49-6301 3205 - 1386

E-mail: info@pfaff-industrial.com